

The power conductor

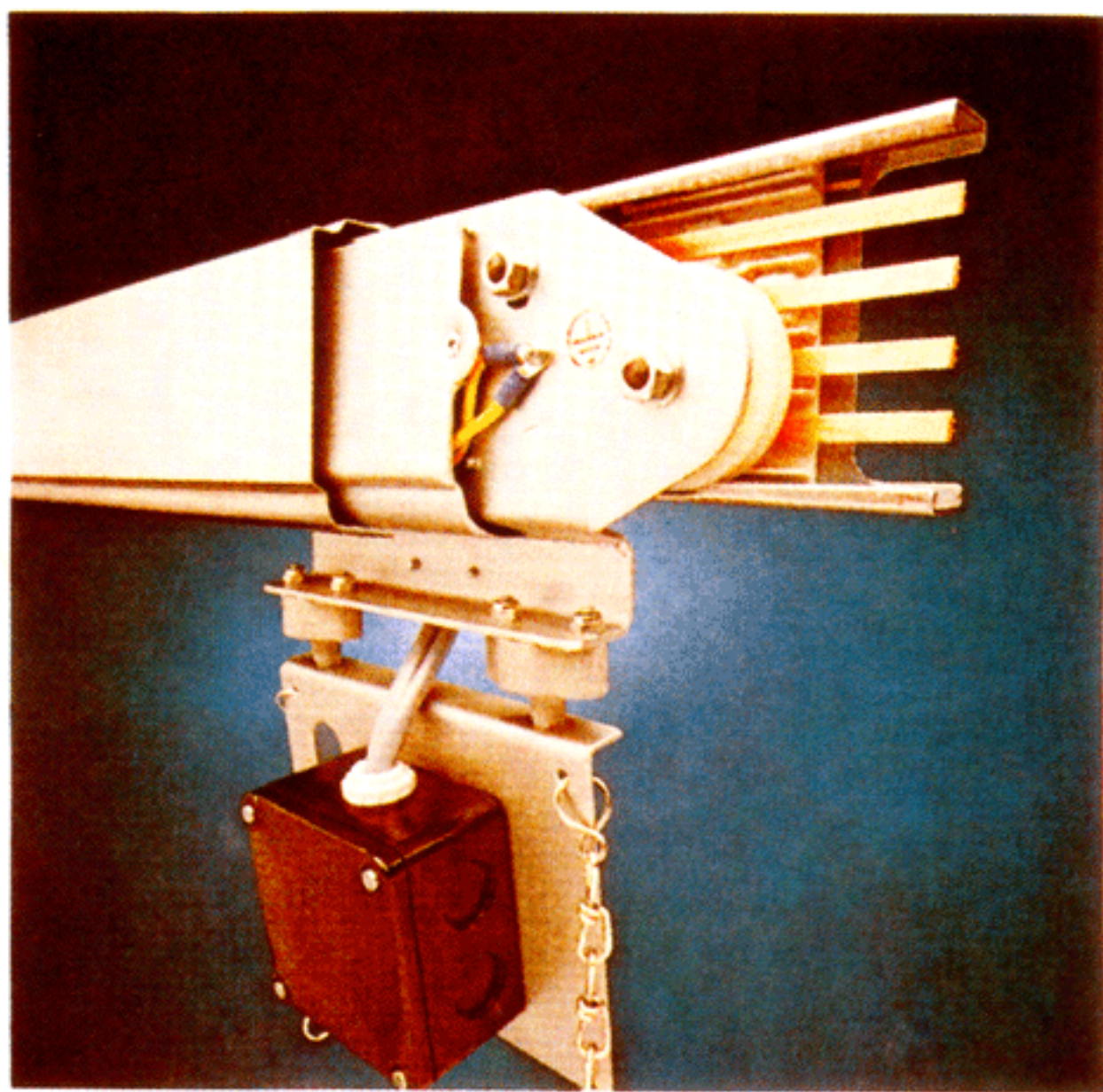

The sheet metal conductor system is a well proven product, it may be used in a large range of application, because of its mechanical strength and its thermal resistance to temperature change (min 40°C to plus 130°C).

The system can house upto 18 conductors in one plane and a capacity rating of 60, 100, 140 and 200 amps. Two types available one for indoor use and the other a weatherproof system for outdoor use. Both types are to VDE and SEV requirements.

**The metal
enclosed
conductor
system**

N D V A

ELECTRICAL CO.



The metal enclosed conductor system SG

Applications for use

The number of pole and amperage ratings must first be determined. The standard size made is 3, 4, 5 and 6 poles with a capacity of 60, 100, 140 and 200 amps. You can combine several conductors is one hanger bracket, details on page 13. The system can house up to 18 conductors in one plane. The SG conductor track can be supplied either in straight, horizontal or vertical curved sections, in special application for transfer stations, switches and turntables, detail on pages 14 and 15.

The Housing

This consists of a twin-shell sheet metal enclosure galvanized by the Sendzimir process, therefore giving a high mechanical strength, and having a mechanical load capacity of up to 50 Kgs per metre when support brackets are installed at 1Mtr intervals. This means in practice you can support power tools and small components from the collector trolley.

The SG conductor track may be installed in temperatures from minus 40°C to plus 130°C. Please state ambient temperature. When ordering conductor track to be installed in temperatures of plus 60°C up to plus 130°C a special insulation can be installed.

The Cover

This is made also from sheet-metal galvanized by the Sendzimir process, thus being resistant to mechanical and temperature damage.

The Insulating Shields & Blocks

These are made from Thermosetting glassreinforced synthetic material. These blocks hold the copper bars in place and at the required distance apart for both the air gap and the tracking minimum distance.

The copper bars are specially made to give a good electrical and mechanical connection. Amperage of copper bars is 60, 100, 140 & 200 amp.

Length of SG Track

Standard lengths supplied are 4.5 Metres. Shorter lengths can be made as required.

Track Installation

This is made by the use of hanger brackets fitted to superstructure. Brackets may be moved horizontal and vertical for final positioning. The track connections are made by a joint plate and connecting sleeves fastened by screws giving a good electrical and mechanical connection.

Electrical Feed Connections

These may be made at any joint between two lengths of track by means of a line feed connection piece. Alternatively, you may also take power from the system for stationary equipment without interrupting the collector trolley movement. Therefore giving you a dual purpose system. The system may be extended or shortened as required using standard parts.

Inspection and Maintenance

This is minimised because you can remove each individual screwed cover for inspection of conductor bars and trolley, but remember to isolate power before carrying out this operation.

The Collector Trolley

This is manufactured from sheet-metal with removable plastic wheels fitted with sealed bearings. The electrical collector housing is made from glass fibre reinforced material with spring loaded copper brushes. Depending upon the amperage required the collector is fitted with more brush holders, sizes available are 25, 40, 50 and 80 amp in one collector trolley.

Inserting and removal of collector trolley

The trolley wheels are set at the factory in the correct place for insertion into the end of a section of track. Alternatively the collector trolley may be installed or removed at any point in the system. Refer to instruction on page 19. The SG system has in its range of standard parts two components to facilitate to removal and insertion of the collector trolley. These parts are the AKLA and AUSV sections, details see page 14 and 15.

Collector Trolley Base Plate

This base plate is used for the purpose of moving the trolley in either direction, it may also house different components such as terminal box, circuit breaker, fuse holders and plug and socket connector.

The SG system at work



Power conductor SG Profile I

up to 5 poles 100 amp capacity

Technical data: number of poles 5 maximum
Capacity 60 and 100 amps
Voltage 0-500V maximum
standard length 4.5 Metres

Curves
Horizontal minimum radius 500 mm
Vertical minimum radius 1500 mm

Please give drawing when requiring a quotation for system with curves. Isolation shields and blocks:

Thermosetting glass reinforced material.

Housing and cover: Cold formed sheet metal zinc-plated as per the Sendzimir process.

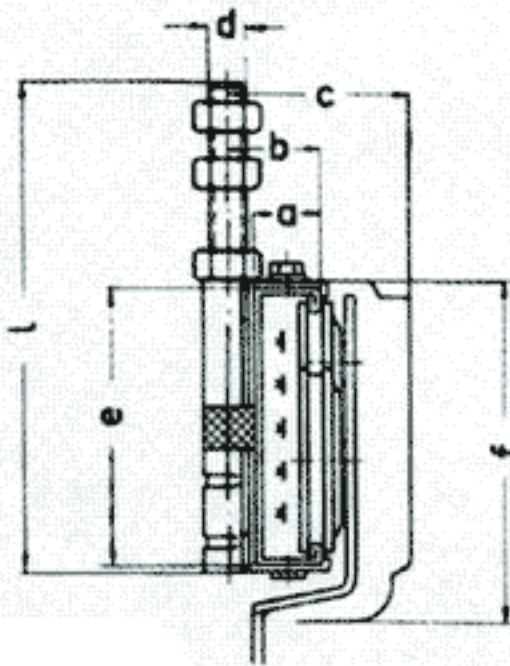

Type poles and capacity

	SG 4/1/60 A	SG 4/1/100 A	SG 5/1/60 A	SG 5/1/100 A
Poles	4	4	5	5
Copper section in mm ²	10	16	10	16
Electrical capacity at 25°C	60 A	100 A	60 A	100 A
Weight per Metre (kg)	4,8	4,9	4,9	5,0
Measurement in mm	a	22	22	22
	b	30	30	30
	c	59	59	59
	d	M 12	M 12	M 12
	e	90	90	90
	f	111	111	111
	l	160	160	160

Additional component parts:

These make for a wider use of the standard design; The following may be used with profile no. I, weatherproofed covers, expansion joints, expansion sections, suspension on adapter, hinged outlet section AKLA, quick release section AUSV, rubber gasket for dust protection. Full details on pages 14 and 15.

Collector Trolley LGB and LGCM

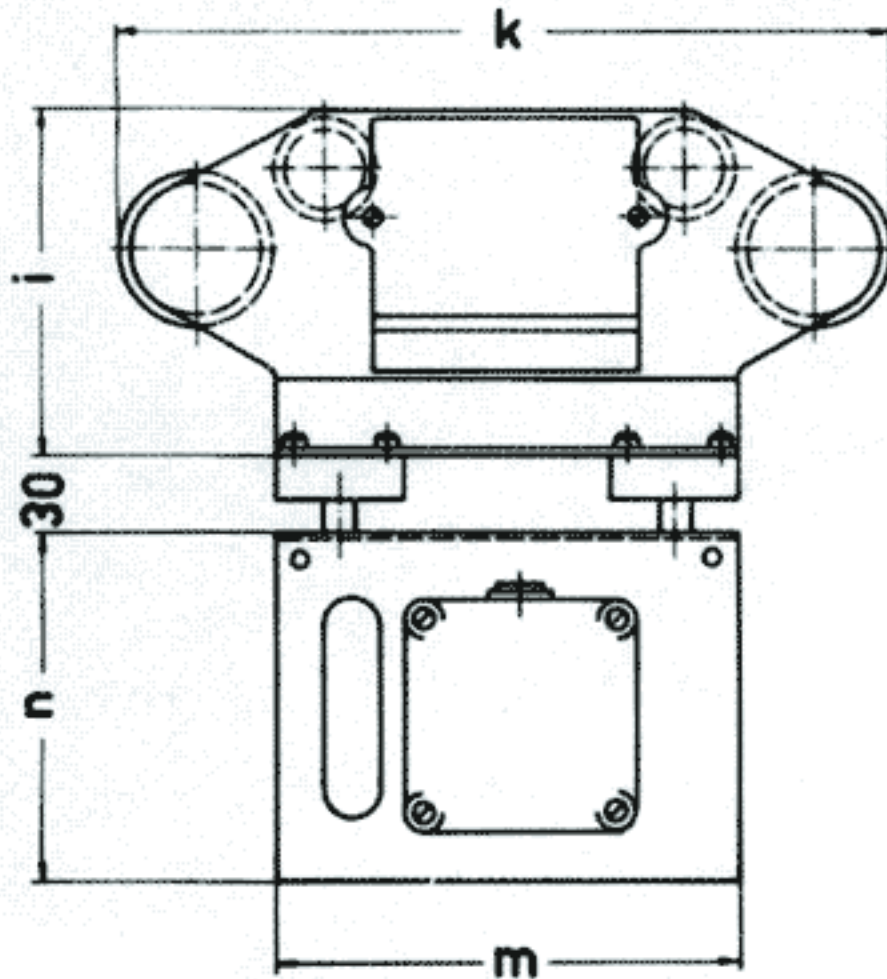

Measurement of collector trolley

	LGB 4/1/EZ	LGC 4/1/EZ	LGCM 4/1/EZ	LGR 4/1/EZ	LGB 5/1/EZ	LGC 5/1/EZ	LGCM 5/1/EZ	LGR 5/1/EZ
Electrical capacity	25 A	50 A	40 A	80 A	25 A	50 A	40 A	80 A
Measurement in mm	i	134	134	134	134	134	134	134
	k	300	430	300	430	300	430	430
	m	180	310	180	310	180	310	310
	n	135	185	135	185	135	185	185

For details of collector trolley and base plate see pages 16 and 17.

Collector Trolley LGC and LGR

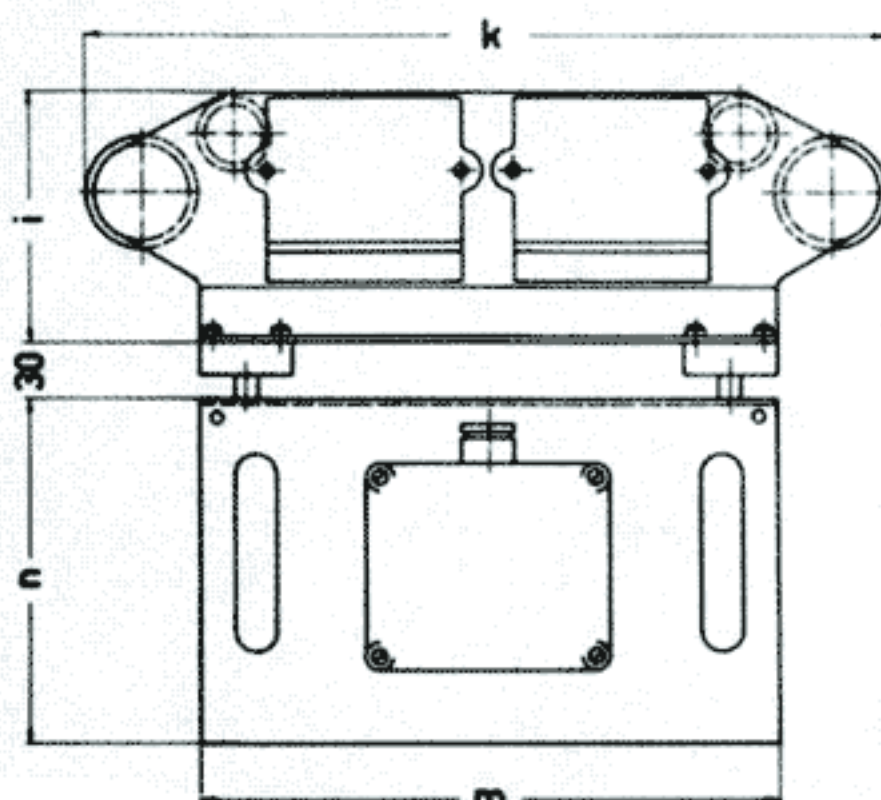

Order example

45 Metres conductor system SG 4/1/100 A consisting of:

- 10 x 4.5 Mts SG 4/1/100 A
- 9 Joint Plates VG 4/1
- 20 Suspension Brackets KG 15/1
- 1 End Feed-In Box EGA 4/1
- 1 End Box EG 1/1
- 1 - Collector Trolley LGB 4/1/EZ

Distance of support brackets

- a) Without load weight = 2.5 Mts
- b) With load up to 30 Kgs = 1.5 Mts
- c) With load up to 50 Kgs = 1.0 Mts

Support bracket galvanized
Normal type for indoor use
type no. KG 15/1

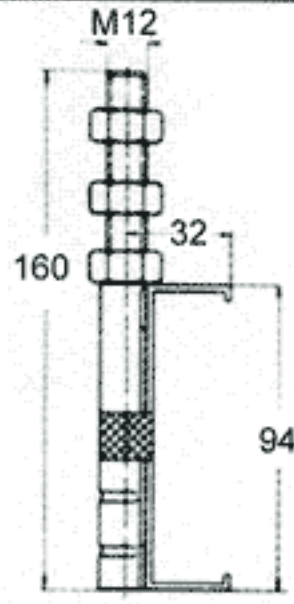

Distance of support brackets

- a) Without load weight = 2.5 Mts
- b) With load up to 30 Kgs = 1.5 Mts
- c) With load up to 50 Kgs = 1.0 Mts

Support bracket galvanized
Weatherproof type for outdoor use
type no. KG 15/1/RG

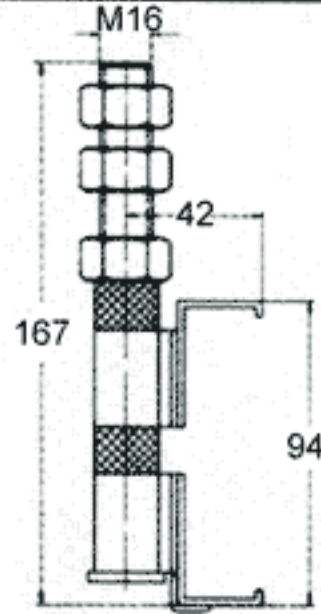

Distance of support brackets

- a) Without load weight = 2.5 Mts
- b) With load up to 30 Kgs = 1.5 Mts
- c) With load up to 50 Kgs = 1.0 Mts

Twin support bracket galvanized
For the combination of two conductor systems, for indoor and outdoor use
type no. KG 30/1/D

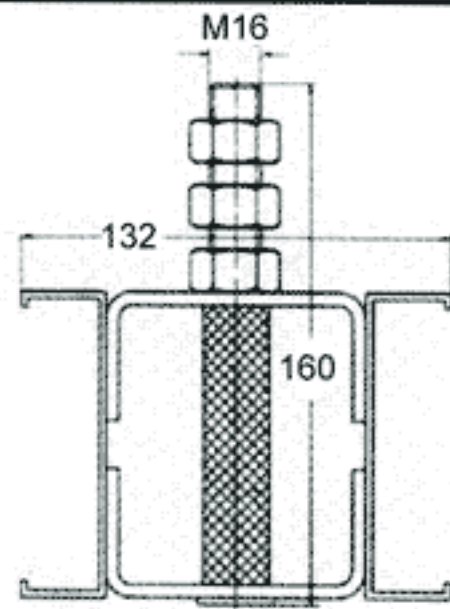

Joint Plate

Sheet metal housing galvanized
cover glass reinforced connecting
sleeves brass nickel plated
with screws.

4 poles type no. VG 4/1
5 poles type no. VG 5/1

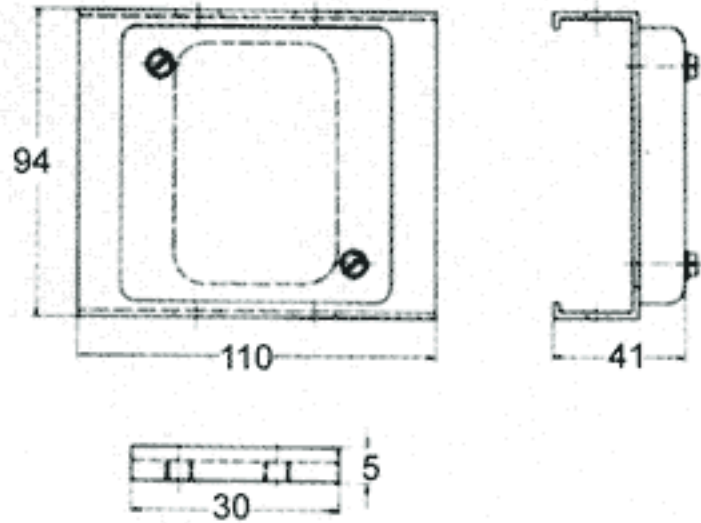

Power feed in box (end feed)

Sheet metal housing galvanized
Cover glass reinforced with
PG 29 gland for cable
Additional length to system
100 mm for connection details
see opposite

4 pole type no. EGA 4/1
5 pole type no. EGA 5/1

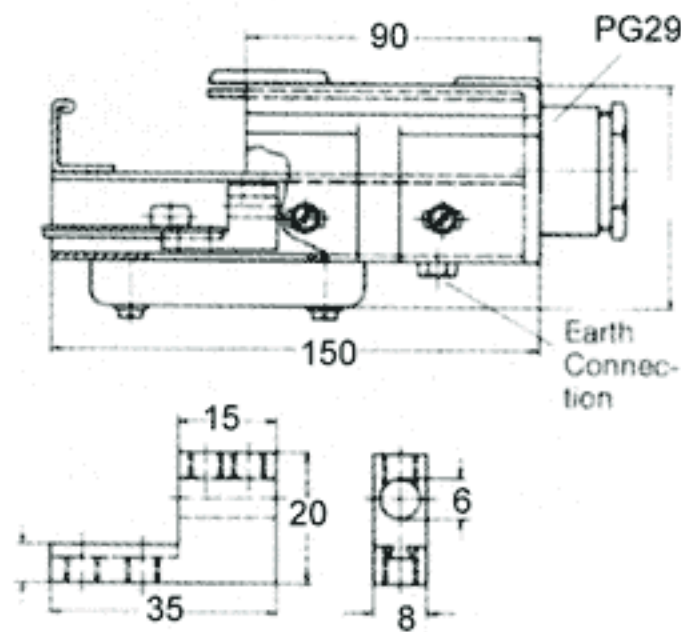

End Box

Sheet metal housing galvanized
cover glass reinforced.

4 and 5 pole type no. EG 1/1

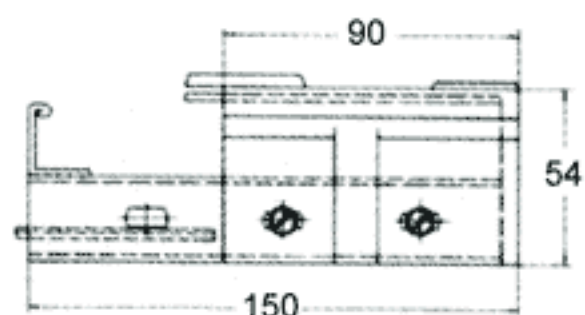

Line feed in section

Sheet metal housing galvanized.
Cover glass reinforced with PG 21
gland for cable.
This section is connected between
two lengths of track. It may be used to
supply the system with the electrical
feed power or be used to feed
stationary equipment without
interrupting the collector trolley
movement. For connection details
see bottom of this page.

4 pole type no. AG 4/1
5 pole type no. AG 5/1

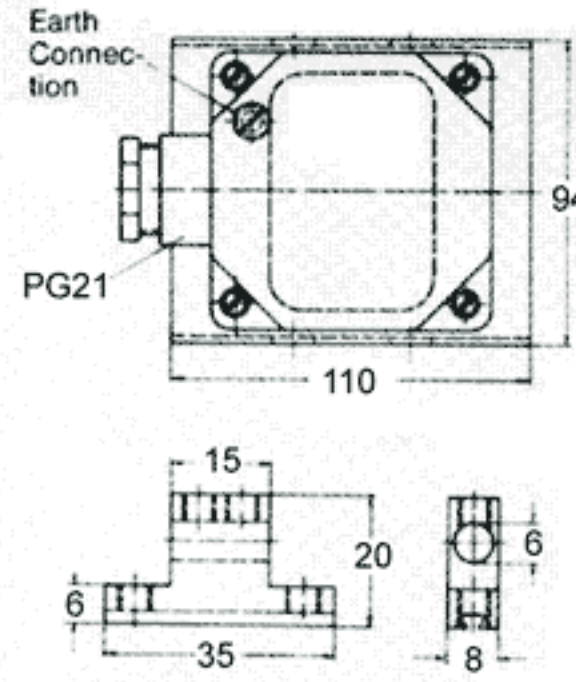

Circuit isolation section (without feed in)

Sheet metal housing and cover
galvanized. This section may be
installed between any two lengths.
Total length of system will increase
by 40 mm.

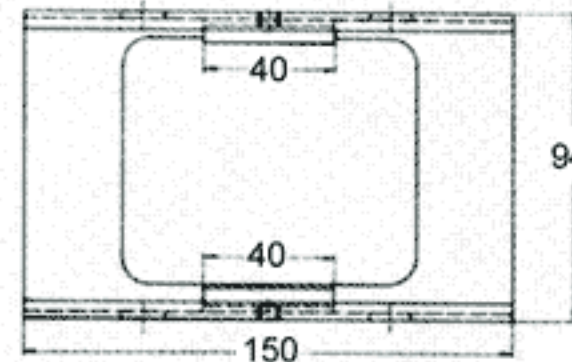

With isolating blocks made of glass
fibre material for conductors nos.
L1, L2, L3 and N.

Copper joint sleeves are used for
PEN and PE.

4 pole type no. TRO 4/1/60A
4 pole type no. TRO 4/1/100A

5 pole type no. TRO 5/1/60A
5 pole type no. TRO 5/1/100A

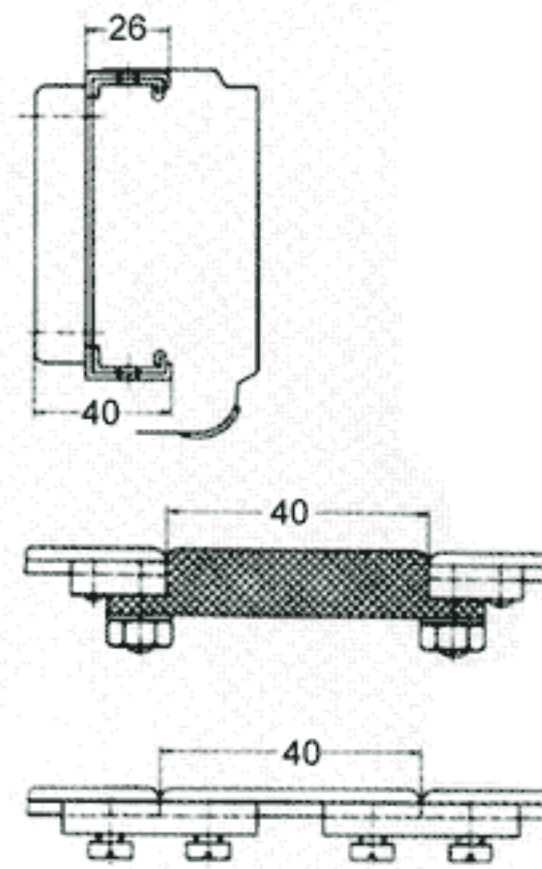

Circuit isolation section (with feed in)

Sheet metal housing and cover
galvanized. This section may be
installed between any two
lengths.

Total length of system will increase
by 40 mm.

With isolating blocks made of glass
fibre and connecting studs for power
feed at each side for conductors nos.
L1, L2, L3 and N.

Copper joint sleeves are used for
PEN and PE with connecting studs.

4 pole type no. TRM 4/1/60A
4 pole type no. TRM 4/1/100A

5 pole type no. TRM 5/1/60A
5 pole type no. TRM 5/1/100A

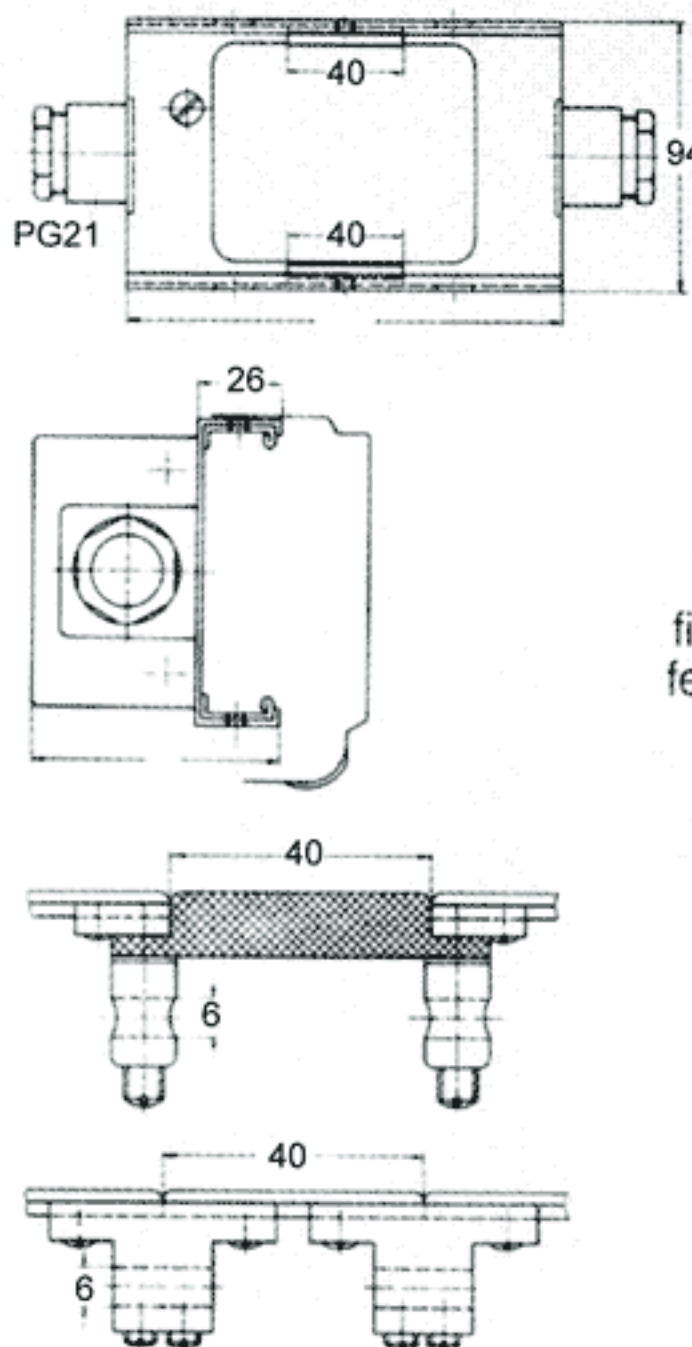

Connection diagram for EGA AG & TRM

4 pole	5 pole
PEN	N
L1	L1
L2	L2
L3	L3
	PE

Power conductor SG Profile II

up to 4 pole 60, 100 and 200 amps

Technical data: number of poles 4 maximum
 Capacity 60, 100, 140 and 200 amps
 Voltage 0–500 V maximum
 standard length 4.5 Metres
 Curves
 Horizontal minimum radius 500 mm
 Vertical minimum radius 1500 mm
 Please give drawing when requiring a quotation for systems with curves. Isolating shields and blocks:
 Thermosetting glass reinforced material.
 Housing and cover: Cold formed sheet metal zinc-plated as per the Sendzmir process.

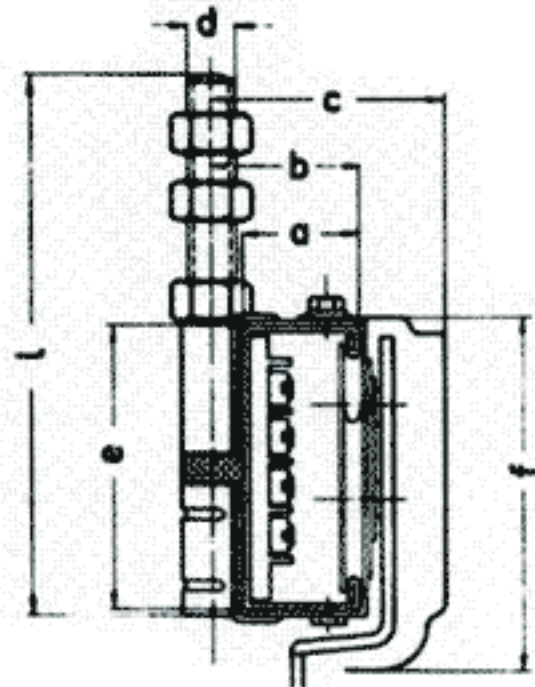

Type poles and capacity

	SG 4/2/60 A	SG 4/2/100 A	SG 4/2/140 A	SG 4/2/200 A
Poles	4	4	4	4
Copper section in mm ²	10	16	40	64
Electrical capacity at 25 °C	60 A	100 A	140 A	200 A
Weight per Metre (kg)	6,2	6,4	7,3	8,2
a	40	40	40	40
b	50	50	50	50
c	83	83	83	83
d	M 16	M 16	M 16	M 16
e	98	98	98	98
f	120,5	120,5	120,5	120,5
l	170	170	170	170

Additional component parts:

These make for a wider use of the standard design; The following may be used with profile no. 2, weatherproofed covers, expansion joints, expansion sections, suspension on adaptor, hinged outlet section AKLA, quick release section AUSV, rubber gasket for dust protection, Bell mouth and transfer sections. Full details on pages 14 and 15.

Measurement of collector trolley

	LGB 4/2/EZ	LGC 4/2/EZ	LGCM 4/2/EZ	LGR 4/2/EZ
Electrical capacity	25 A	50 A	40 A	80 A
i	140	140	140	140
k	300	430	300	430
m	180	310	180	310
n	135	185	135	185

For details of collector trolley and base plate see pages 16 and 17.

Order example

37 Metres conductor system SG 4/2/200 A consisting of:
 8 x 4.5 Mtrs SG 4/2/200 A
 1 x 1.0 Mtr Line Feed Section AG 4/2/200 A
 8 Joint Plates VG 2/200 A
 25 Suspension Brackets KG 15/2
 2 End Boxes EG 1/2
 2 Collector Trolleys type LGB 4/2/EZ

Collector Trolley LGB and LGCM

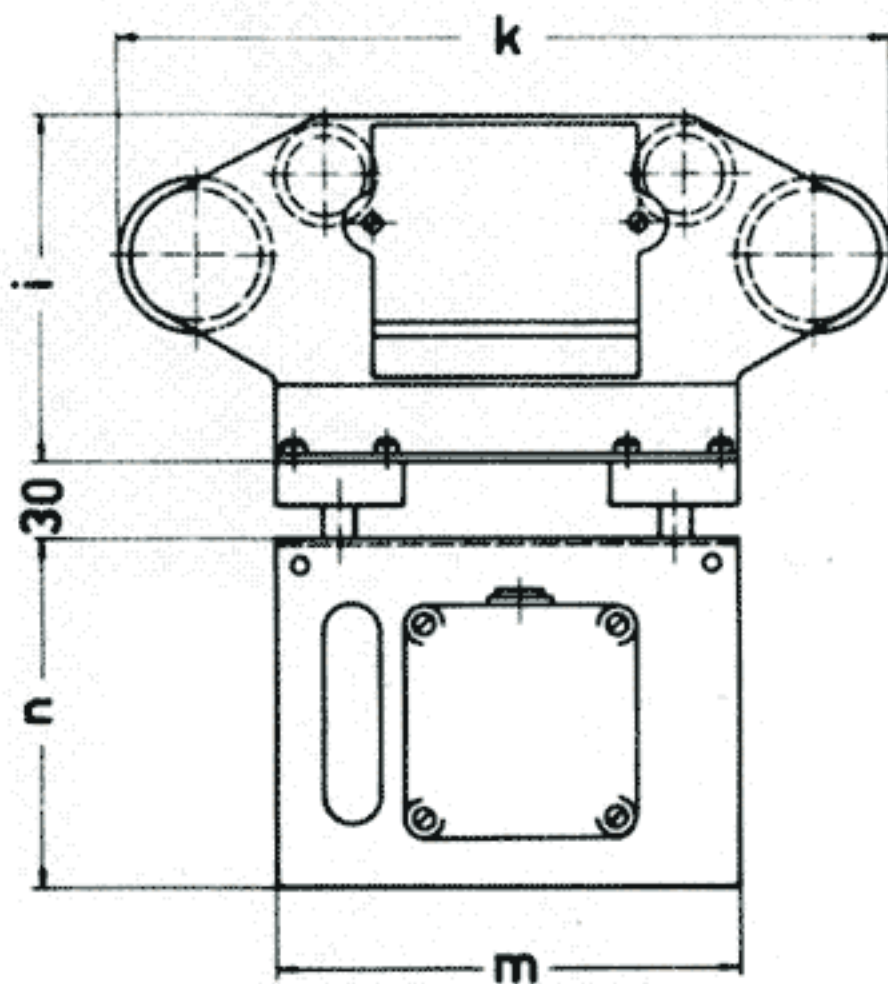

Collector Trolley LGC and LGR

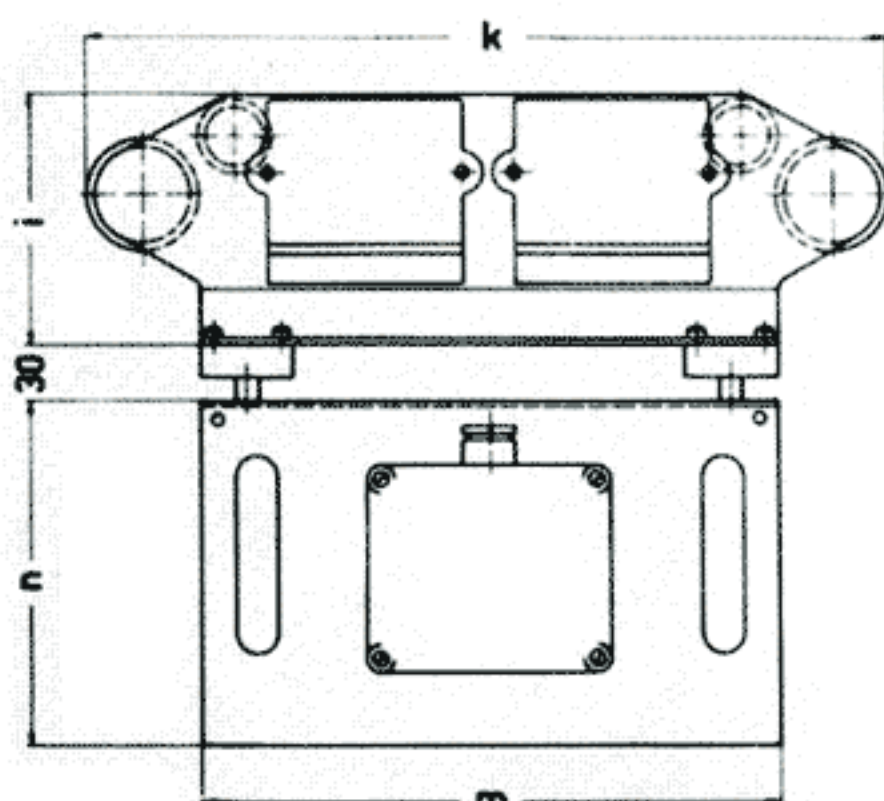

Distance of support brackets for Profile II 60 and 100 A

- a) Without load weight = 2.5 Mts
- b) With load up to 30 Kgs = 1.5 Mts
- c) With load up to 50 Kgs = 1.0 Mts

Distance of support brackets for Profile II 140 and 200 A

Without load weight = 1.5 Mts
 With load up to 50 Kgs = 1.0 Mts
 Support bracket galvanized.
 Normal type for indoor use
 type no. KG 15/2.

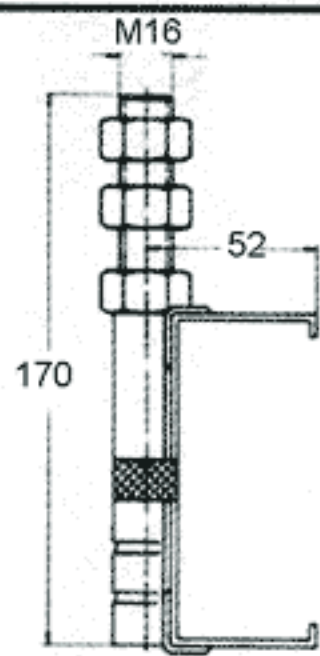

Distance of support brackets for Profile II 60 and 100 A

- a) Without load weight = 2.5 Mts
- b) With load up to 30 Kgs = 1.5 Mts
- c) With load up to 50 Kgs = 1.0 Mts

Distance of support brackets for Profile II 140 and 200 A

Without load weight = 1.5 Mts
 With load up to 50 Kgs = 1.0 Mts
 Weatherproofed type galvanized for outdoor use.
 Type no. KG 15/2/RG

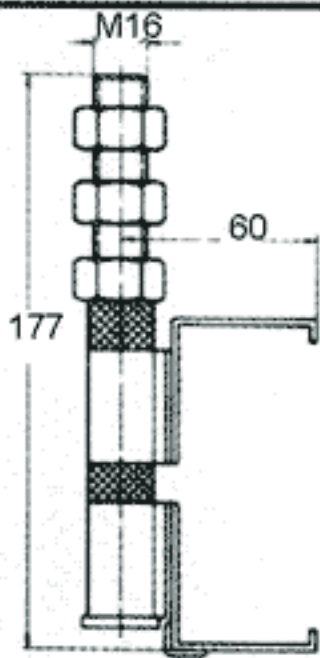

Distance of support brackets for profile II 60 and 100 A

- a) Without load weight = 2.5 Mts
- b) With load up to 30 Kgs = 1.5 Mts
- c) With load up to 50 Kgs = 1.0 Mts

Distance of support brackets for profile II 140 and 200 A

Without load weight = 1.5 Mts
 With load up to 50 Kgs = 1.0 Mts
 Twin support bracket galvanized for the combination of two conductor systems for indoor and outdoor use.
 Type no. KG 30/2/D

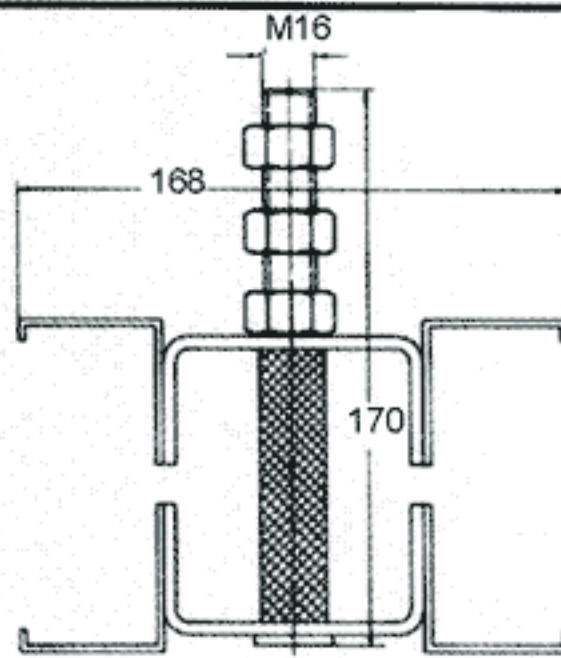

Joint Plate

Sheet metal housing galvanized cover glass reinforced connecting sleeves brass nickel plated with screws.

4 poles type no. VG 4/1
5 poles type no. VG 5/1

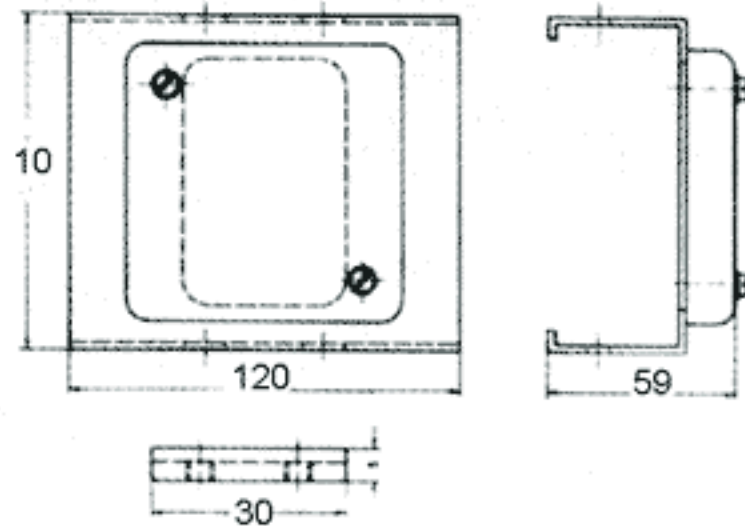

Power feed in box (end feed)

4 pole 60 and 100 Amp

Sheet metal housing galvanized. Cover glass fibre with PG 21 gland for cable. Additional length to system 100 mm
 For connection details see opposite.

4 pole 140 and 200 A

This part is fitted into a 1 Mtr track section with a sheet steel cover, cable connectors for cable sizes 25 to 120 mm²
 For connection details see opposite.

4 pole 140 and 200 A

Type no. EGA 4/2/140 A
 Type no. EGA 4/2/200 A

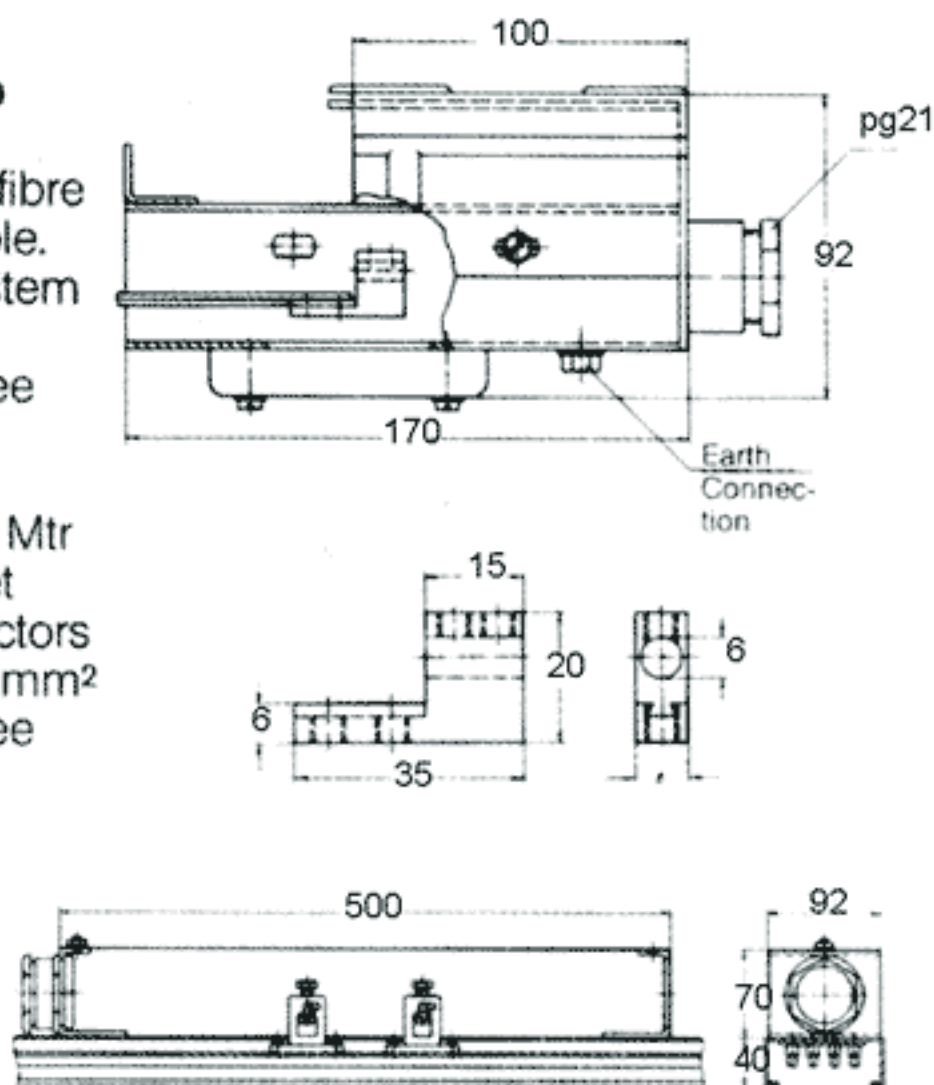

End Box

Sheet metal housing galvanized cover glass fibre
 Type no. EG 1/2

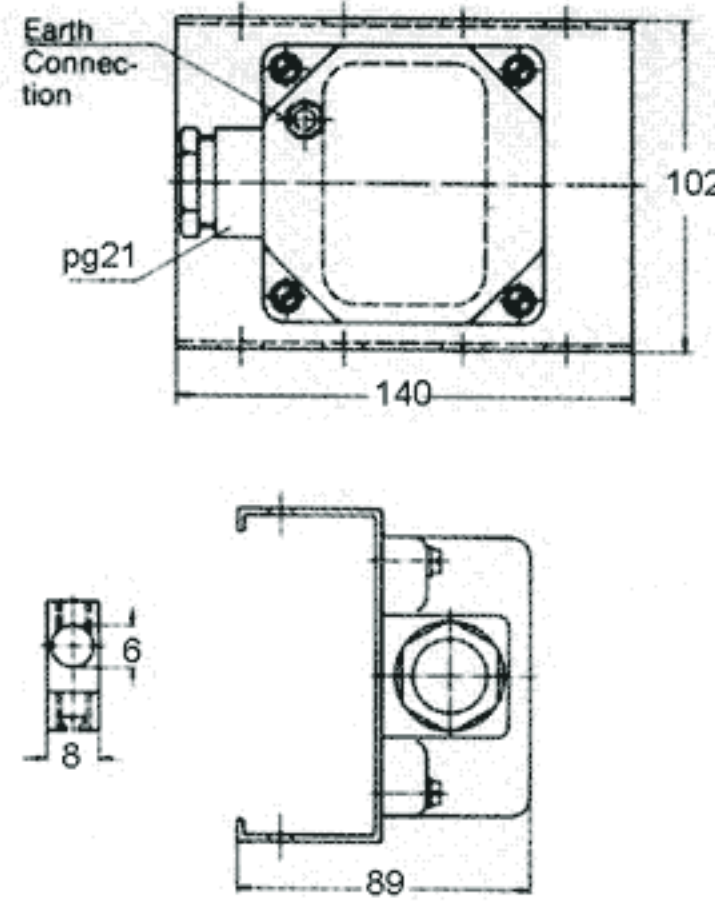
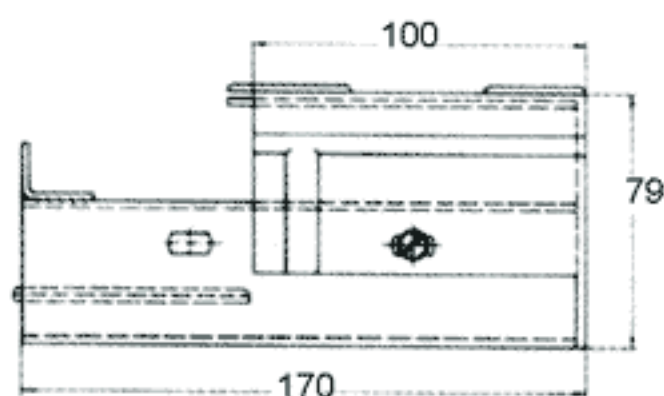

Line feed in section

Sheet metal housing galvanized cover glass fibre with PG 21 gland for cable. For connection details see bottom of this page.

For 60 and 100 A Type no. AG 4/2/100 A

4 pole 140 and 200 A

This part is fitted into a 1 Mtr track section with a steel cover, cable connectors for cable sizes 25 to 120 mm².

For connection details see Type no. AG 4/2/140 A
 Type no. AG 4/2/200 A

Circuit isolation section (without feed in)

Sheet metal housing and cover galvanized. This section may be installed between any two lengths. Total length of system will increase by 40 mm.

With isolating blocks made of glass fibre material for conductors nos. L1, L2, L3 and N. Copper joint sleeves are used for PEN and PE.

4 pole type no. TRO 4/2/ 60 A
 4 pole type no. TRO 4/2/100 A
 4 pole type no. TRO 4/2/140 A
 4 pole type no. TRO 4/2/200 A

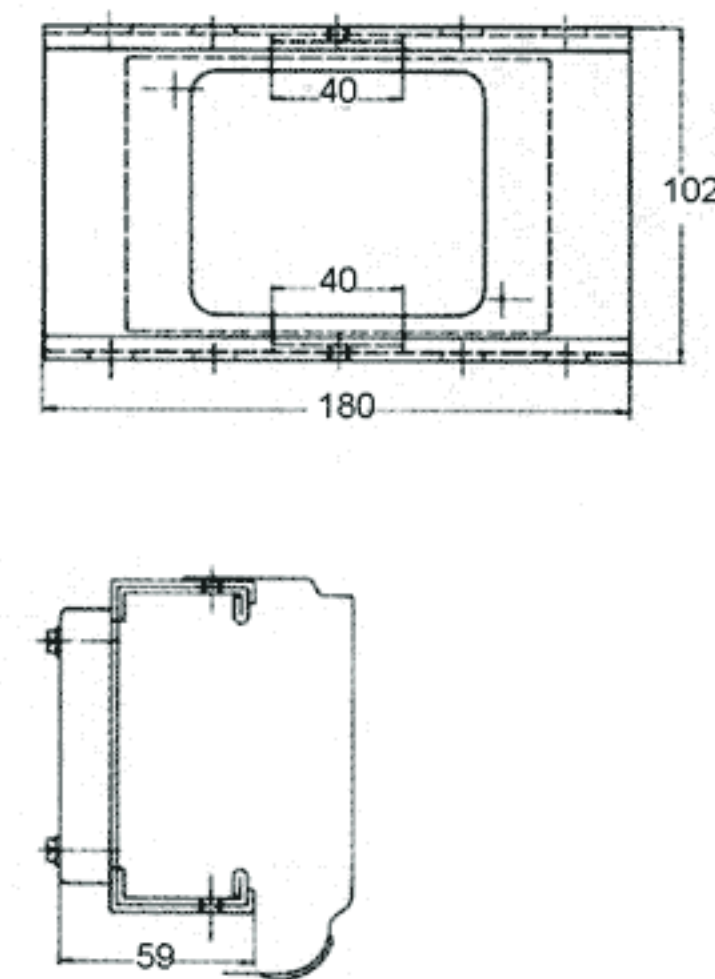

Circuit isolation section (with feed in) for 60 and 100 AMPS

Sheet metal housing and cover galvanized. This section may be installed between any two lengths. Total length of system will increase by 40 mm.

This isolating blocks are of glass fibre material and connecting studs for power feeds at each side for conductors nos. L1, L2, L3. Copper joint sleeves are used for PEN with connecting studs

Type no. TRM 4/2/ 60 A
 Type no. TRM 4/2/100 A

4 pole 140 and 200 A

This part is fitted into a 1 Mtr track section with a sheet steel cover, cable connectors for cable sizes 25 to 120 mm². The isolating blocks are made of glass fibre material with connecting studs for power feed at each side for conductors nos L1, L2, L3. Copper joint sleeves are used for PEN with connecting studs
 Type no. TRM 4/2/140 A
 Type no. TRM 4/2/200 A

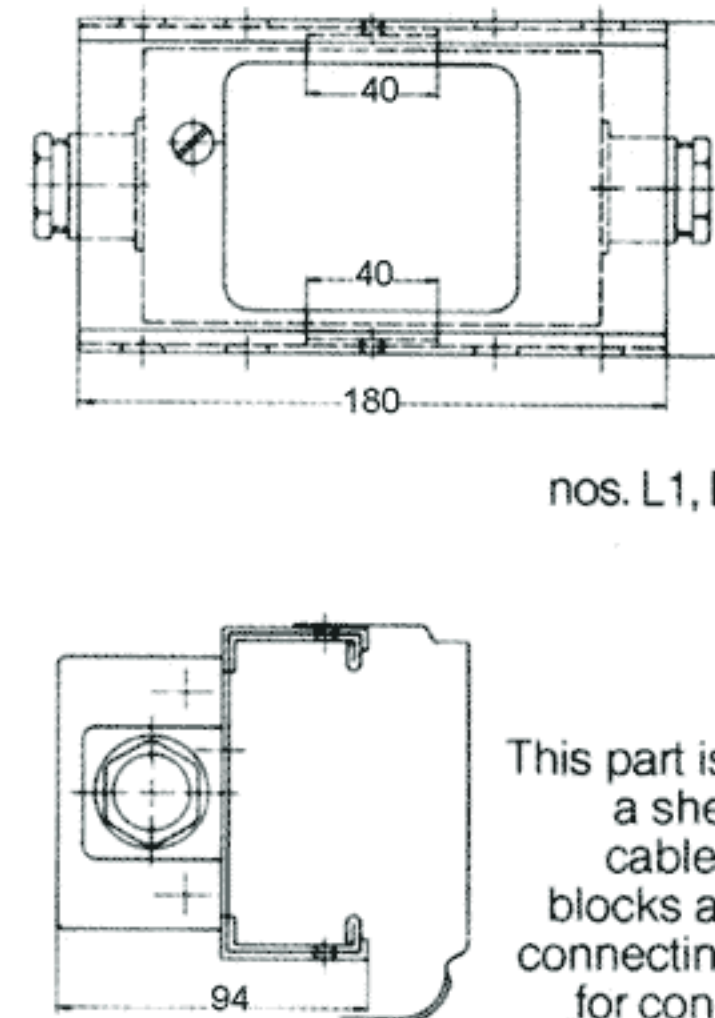

Connection diagram for EGA AG & TRM 4 Pole

PEN
L 1
L 2
L 3

Power conductor SG Profile III

up to 6 poles 60, 100, 140 and 200 Amps

Technical data: number of poles 6 maximum
Capacity 60, 100, 140 and 200 amps
Voltage 0-500 V maximum
standard length 4.5 Metres

Curves
Horizontal minimum radius 500 mm
Vertical minimum radius 1500 mm

Please give drawing when requiring a quotation for systems with curves. Isolating shields and blocks:
Thermosetting glass reinforced material.
Housing and cover: Cold formed sheet metal zinc-plated as per the sendzmir process.

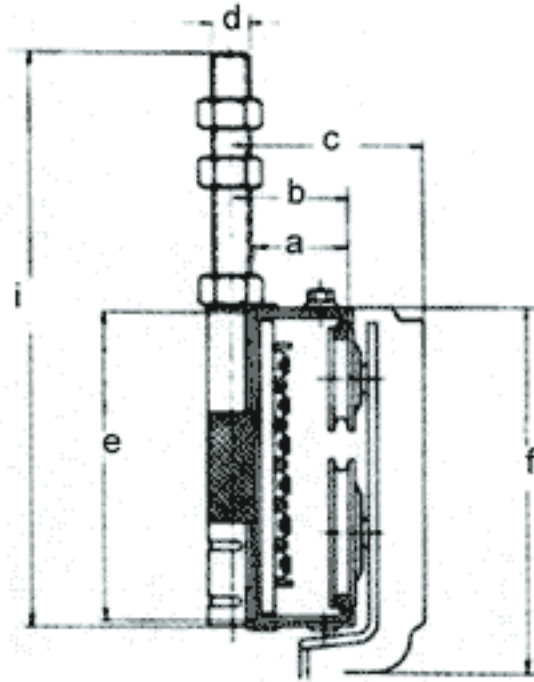

Type poles and capacity

	SG 5/3/60A	SG 5/3/100A	SG 5/3/140A	SG 5/3/200A	SG 6/3/60A	SG 6/3/100A	SG 6/3/140A	SG 6/3/200A
Poles	5	5	5	5	6	6	6	6
Copper section in mm ²	10	16	40	64	10	16	40	64
Electrical capacity at 25°C	60A	100A	140A	200A	60A	100A	140A	200A
Weight per Metre (kg)	7,48	7,75	8,55	9,62	7,57	7,90	8,91	10,2
Measurement in mm	a	40	40	40	40	40	40	40
	b	50	50	50	50	50	50	50
	c	83	83	83	83	83	83	83
	d	M16	M16	M16	M16	M16	M16	M16
	e	132	132	132	132	132	132	132
	f	154,5	154,5	154,5	154,5	154,5	154,5	154,5
	l	210	210	210	210	210	210	210

Additional component parts:

These make for a wider use of the standard design; The following may be used with profile no. 3, weatherproofed covers, expansion joints, expansion sections, suspension on adaptor, hinged outlet section AKLA, quick release section AUSV, rubber gasket for dust protection, Bell mouth and transfer sections. Full details on pages 14 and 15.

Measurement of collector trolley

	LGB 5/3/EZ	LGC 5/3/EZ	LGCM 5/3/EZ	LGR 5/3/EZ	LGB 6/3/EZ	LGC 6/3/EZ	LGCM 6/3/EZ	LGR 6/3/EZ
Electrical capacity	25A	50A	40A	80A	25A	50A	40A	80A
Measurement in mm	i	170	170	170	170	170	170	170
	k	285	412	285	412	285	412	412
	m	180	310	180	310	180	310	310
	n	185	185	185	185	185	185	185

For details of collector trolley and base plate see pages 16 and 17.

Order example

50 Metres conductor system SG 6/3/60 A
Consisting of:
11 x 4.5 Mtrs SG 6/3/60 Amp
1 x 0.5 Mtr SG 6/3/60 Amp
11 Joint Plates VG 6/3/50 Amp
34 Suspension Brackets KG 15/3
1 End Feed-In Box EGA 6/3/60 Amp
1 End Box EG 1/3
1 Collector Trolley LGB 6/3/EZ

Collector Trolley
LGB and LGCM

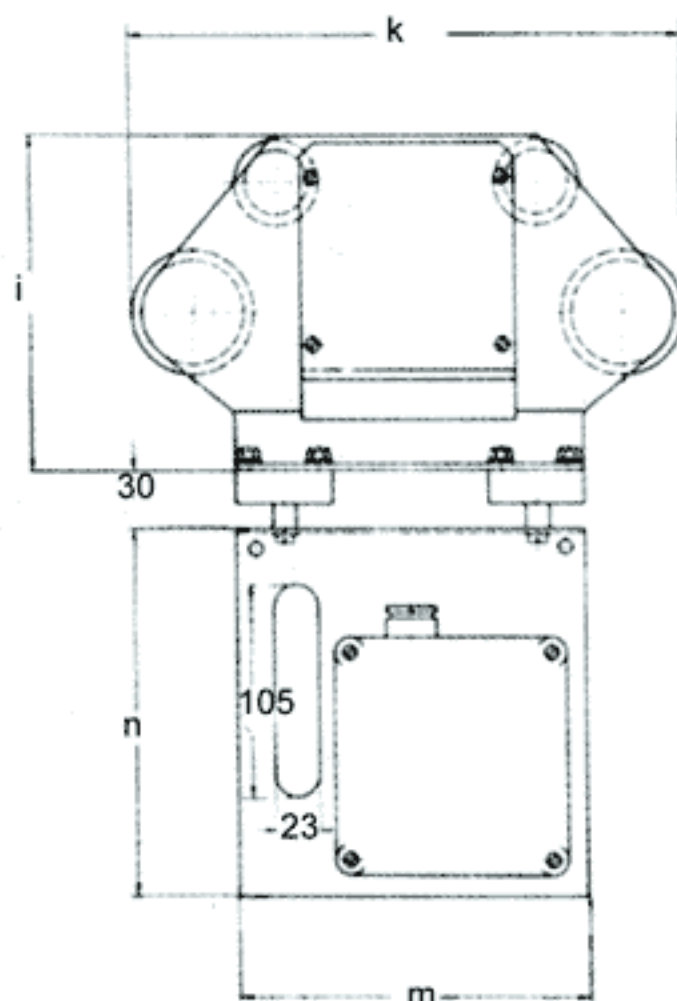

Collector Trolley
LGC and LGR

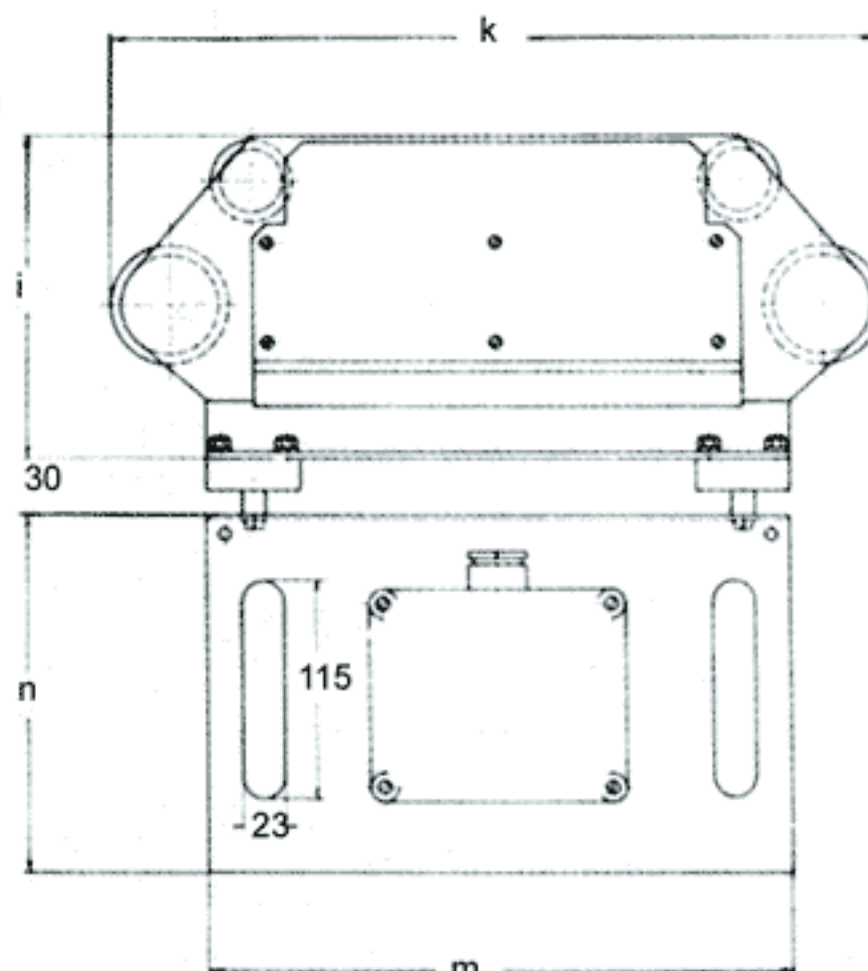

Distance of support brackets

- a) Without load weight = 1.5 Mts
- b) With load up to 50 Kgs = 1.0 Mts

Support bracket galvanized
Normal type for indoor use
Type no. KG 15/3

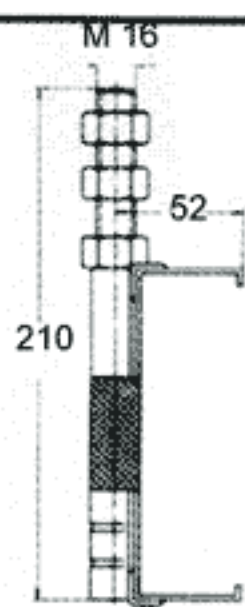

Distance of support brackets

- a) Without load weight = 1.5 Mts
- b) With load up to 50 Kgs = 1.0 Mts

Support brackets galvanized
Weatherproof type for outdoor use
Type no. KG 15/3/RG

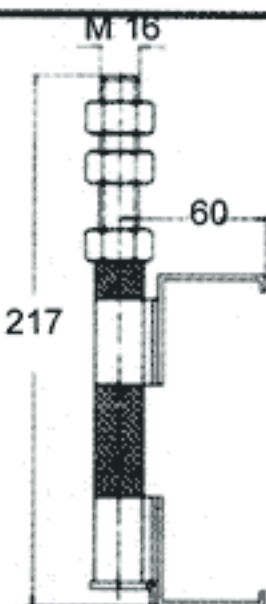

Distance of support brackets

- a) Without load weight = 1.5 Mts
- b) With load up to 50 Kgs = 1.0 Mts

Support bracket galvanized
Twin support bracket for the combination
of two conductor system for indoor and
outdoor use
Type no. KG 30/3/D

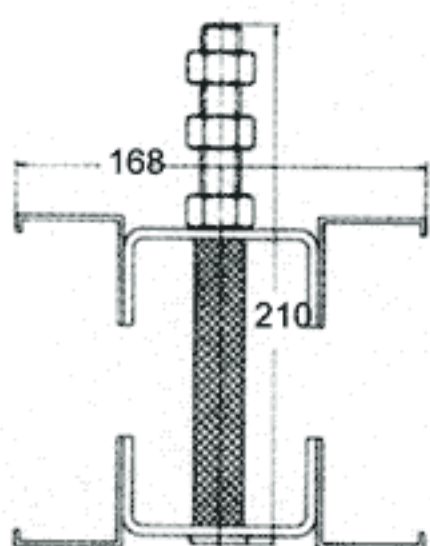

Joint Plate

Sheet metal housing galvanized
cover glass reinforced connecting
sleeves brass nickel plated with
screws.

- 5 pole type no. VG 5/3/100 A
- 6 pole type no. VG 6/3/100 A
- 5 pole type no. VG 5/3/200 A
- 6 pole type no. VG 6/3/200 A

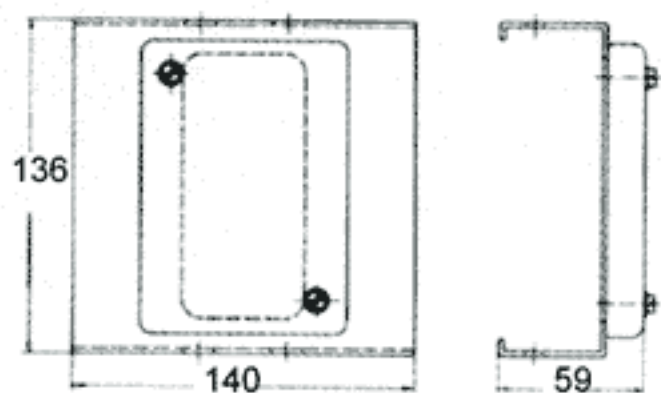

**Power Feed-In box
(end feed)**

5 and 6 pole 60 and 100 Amp

Sheet metal housing
galvanized. Cover glass fibre
with PG 21 gland for cable.
Additional length to system
100 mm
For connection details see
opposite.

**5 and 6 pole 140 and
200 Amp**

This part is fitted into a 1 Mtr
track section with a sheet steel
cover, cable connectors for cable sizes 25
to 120 mm²

For connection details see opposite.

5 and 6 pole 140 and 200 Amp

- 5 pole type no. EGA 5/3/140 A
- 5 pole type no. EGA 5/3/200 A
- 6 pole type no. EGA 6/3/140 A
- 6 pole type no. EGA 6/3/200 A

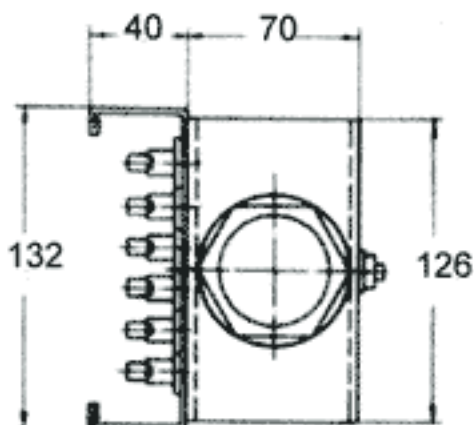
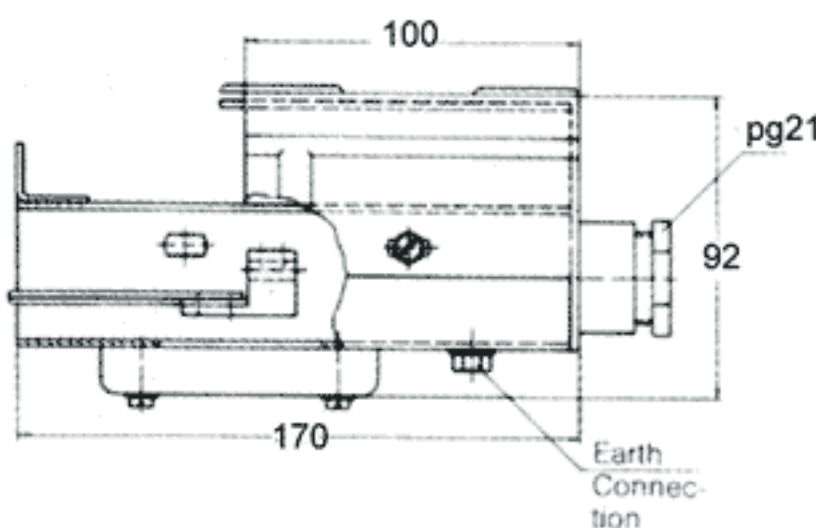

End Box

Sheet metal housing galvanized cover
glass fibre
Type no. EG 1/3

Line Feed-In section

5 and 6 pole 60 and 100 Amp

Sheet metal housing galvanized cover
glass fibre with PG 21 gland for cable.
For connection details see bottom of this
page.

- 5 pole type no. AG 5/3/100 A
- 6 pole type no. AG 6/3/100 A

5 and 6 pole 140 and 200 Amp

This part is fitted into a 1 Mtr track
section with a sheet cover, cable
connectors for cable sizes 25 to 120 mm²

For connection details see

- 5 pole type no. AG 5/3/140 A
- 6 pole type no. AG 6/3/140 A
- 5 pole type no. AG 5/3/200 A
- 6 pole type no. AG 6/3/200 A

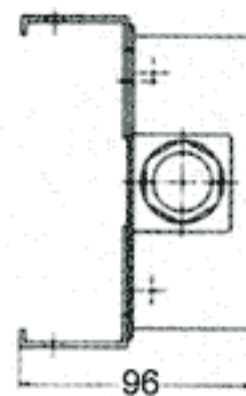
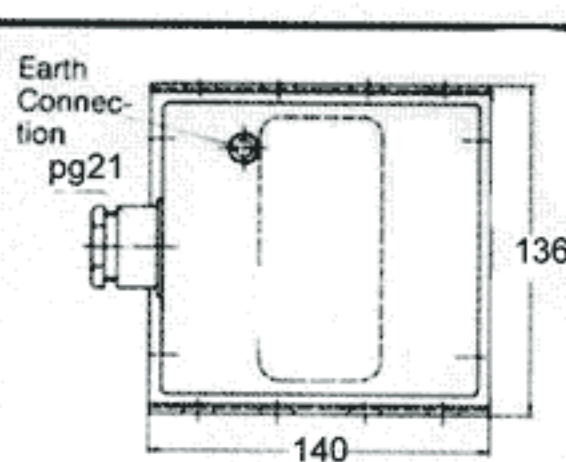

**Circuit isolating section
(without Feed-In)**

Sheet metal housing and cover
galvanized. This section may be installed
between any two lengths.
Total length of system will increase
by 40 mm.

- 5 pole type no. AG 5/3/ 60 A
- 5 pole type no. AG 5/3/100 A
- 5 pole type no. AG 5/3/140 A
- 5 pole type no. AG 5/3/200 A
- 6 pole type no. AG 6/3/ 60 A
- 6 pole type no. AG 6/3/100 A
- 6 pole type no. AG 6/3/140 A
- 6 pole type no. AG 6/3/200 A

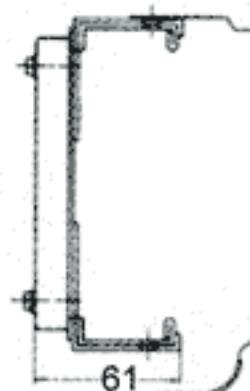
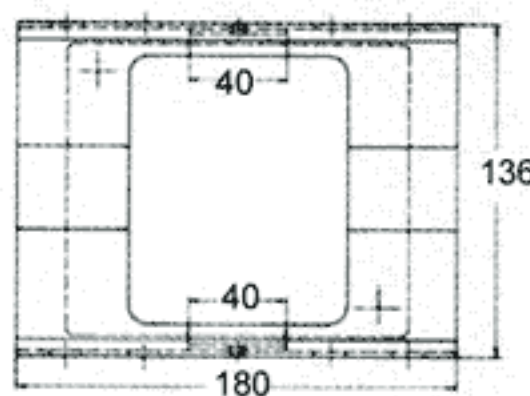

**Circuit isolating section
(with Feed-In) for 60 and 100 amps**

Sheet metal housing and cover
galvanized. This section may be
installed between any two lengths.
Total length of system will increase
by 40 mm. The isolating blocks are of
glass fibre material and connecting
studs for power feeds at each side for
conductors nos. L1, L2, L3. Copper joint
sleeves are used for PEN with
connecting studs

- Type no. TRM 5/3/ 60 A
- Type no. TRM 5/3/100 A
- Type no. TRM 6/3/ 60 A
- Type no. TRM 6/3/100 A

5 and 6 poles 140 and 200 A

This part is fitted into a 1 Mtr track
section with a sheet steel cover, cable
connectors for cable sizes 25 to
120 mm². The isolating blocks are
made of glass fibre material with
connecting studs for power feed at
each side for conductors nos. L1, L2,
L3. Copper joint sleeves are used for
not interrupted conductors complete
with connecting studs. For connecting
details see bottom of page.

- Type no. TRM 5/3/140 A
- Type no. TRM 6/3/140 A
- Type no. TRM 5/3/200 A
- Type no. TRM 6/3/200 A

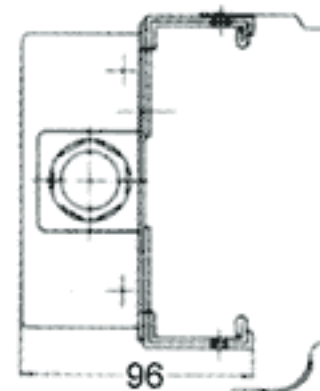
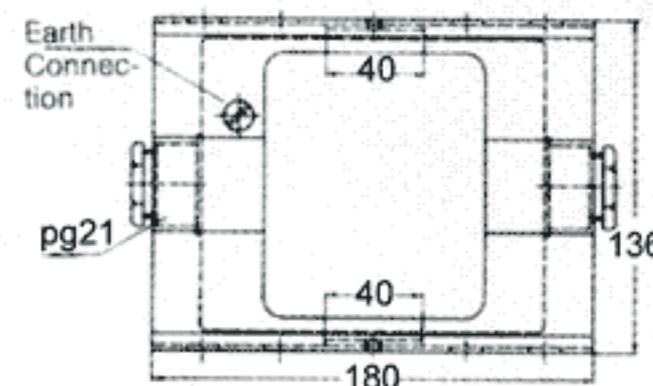

Connection diagram for EGA AG & TRM

5 Pole	6 Pole
PE	PEN
L 1	L 1
L 2	L 2
L 3	L 3
N	L 4
	L 5

Power conductor SG Profile IV

up to 18 poles 60, 100, 140 and 200 Amps

Technical data: number of poles 18 maximum
 Capacity 60, 100, 140 and 200 amps
 Voltage 0-500 V maximum
 standard length 4.5 Metres
 Curves
 Horizontal minimum radius 500 mm
 Vertical minimum radius 1500 mm
 Please give drawing when requiring a quotation for systems with curves. Isolating shields and blocks:
 Thermosetting glass reinforced material.
 Housing and cover: Cold formed sheet metal zinc-plated as per the Sendzmir process.

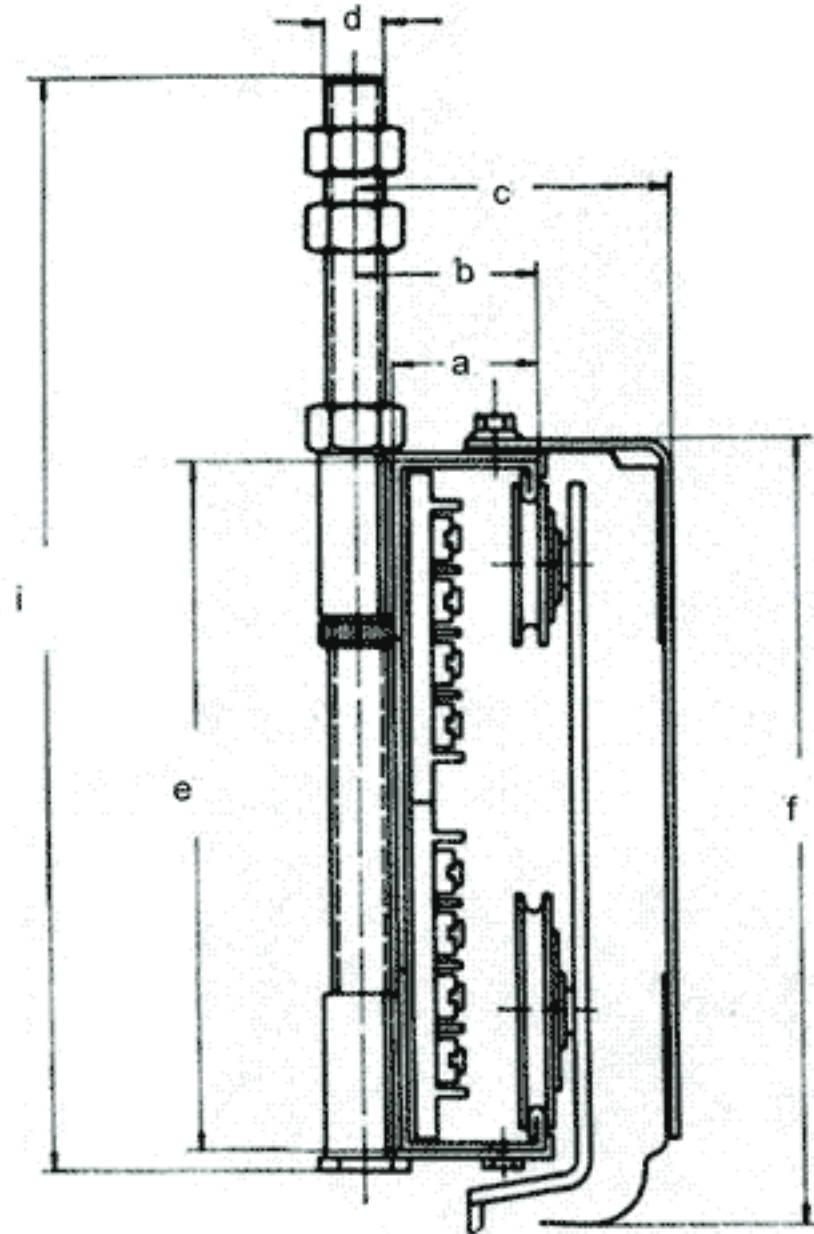

Type, number of poles and capacity.

	SG 7/4/60 A 100 A/140 A/200 A	SG 8/4/60 A 100 A/140 A/200 A	SG 9/4/60 A/100 A 140 A/140 A/200 A	SG 10/4/60 A 100 A/140 A/200 A	SG 11/4/60 A 100 A/140 A/200 A	SG 12/4/60 A 100 A/140 A/200 A	SG 13/4/60 A 100 A/140 A/200 A	SG 14/4/60 A 100 A/140 A/200 A	SG 15/4/60 A 100 A/140 A/200 A	SG 16/4/60 A 100 A/140 A/200 A	SG 17/4/60 A 100 A/140 A/200 A	SG 18/4/60 A 100 A/140 A/200 A
Poles	7	8	9	10	11	12	13	14	15	16	17	18
Copper Section	10-64	10-64	10-64	10-64	10-64	10-64	10-64	10-64	10-64	10-64	10-64	10-64
Electrical Capacity	60 - 200 A	60 - 200 A	60 - 200 A	60 - 200 A	60 - 200 A	60 - 200 A	60 - 200 A	60 - 200 A	60 - 200 A	60 - 200 A	60 - 200 A	60 - 200 A
Weight per Mtr.	12 - 15,7	12 - 15,7	13,7 18,5	13,7 18,5	16,8 - 22,6	16,8 22,6	19,8 - 26,5	19,8 - 26,5	22 - 29,6	22 - 29,6	23,8 - 32,5	23,8 - 32,5
a	40	40	40	40	40	40	40	40	40	40	40	40
b	50	50	50	50	50	50	50	50	50	50	50	50
c	86	86	87	87	90	90	90	90	90	90	90	90
d	M 16	M 16	M 16	M 16	M 16	M 16	M 16	M 16	M 16	M 16	M 16	M 16
e	189,5	189,5	223,5	223,5	257,5	257,5	315	315	349	349	383	383
f	214	214	249	249	286	286	343	343	377	377	412	412
l	265	265	305	305	390	390	390	460	460	490	490	520

Measurement
in mm

Additional component parts:

These make for a wider use of the standard design; The following may be used with profile no. 4 weatherproofed covers, expansion joints, expansion sections, suspension on adaptor, hinged outlet section AKLA, quick release section AUSV, rubber gasket for dust protection, Bell mouth and transfer sections. Full details on pages 14 and 15.

Order example for 16 poles 100 Amp

36 Metres conductor system SG 16/4/100 A
 Consisting of:
 8 x 4.5 Mts SG 16/4/100 A
 7 x Joint Plates VG 16/4/100 A
 36 Suspension Brackets KG 15/4/16
 1 End Feed in Box EGA 16/4/100 A
 1 End Box EG 1/4/16
 1 Collector Trolley LGB 16/4/EZ/M

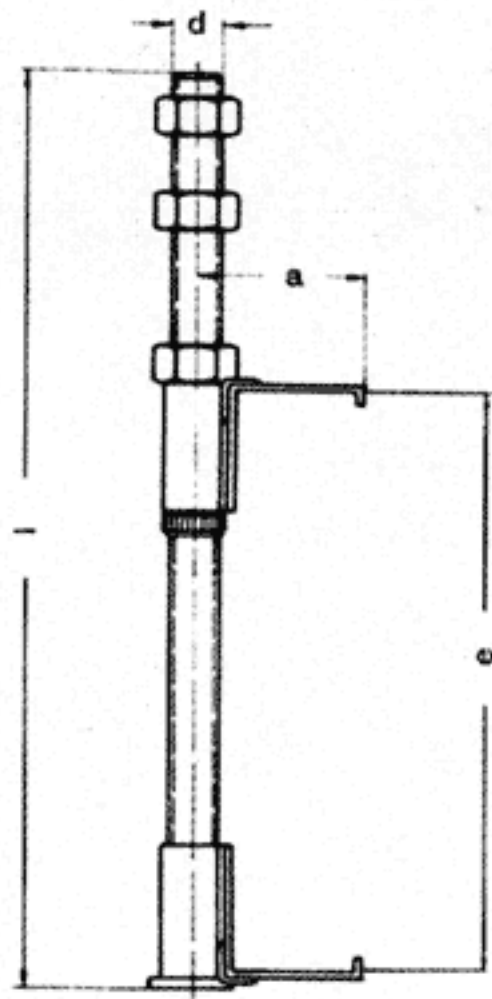

Distance of support brackets
for profile 4 = 1.0 Mts

Support bracket KG 15/4 Galvanized

Measurement in mm	Type no. of poles					
	KG 15/4/7/8	KG 15/4/9/10	KG 15/4/11/12	KG 15/4/13/14	KG 15/4/15/16	KG 15/4/17/18
a	52	52	52	52	52	52
d	M 16	M 16	M 16	M 16	M 16	M 16
e	189,5	223,5	257,5	315	349	383
l	265	305	390	460	490	520

Also weatherproof type available

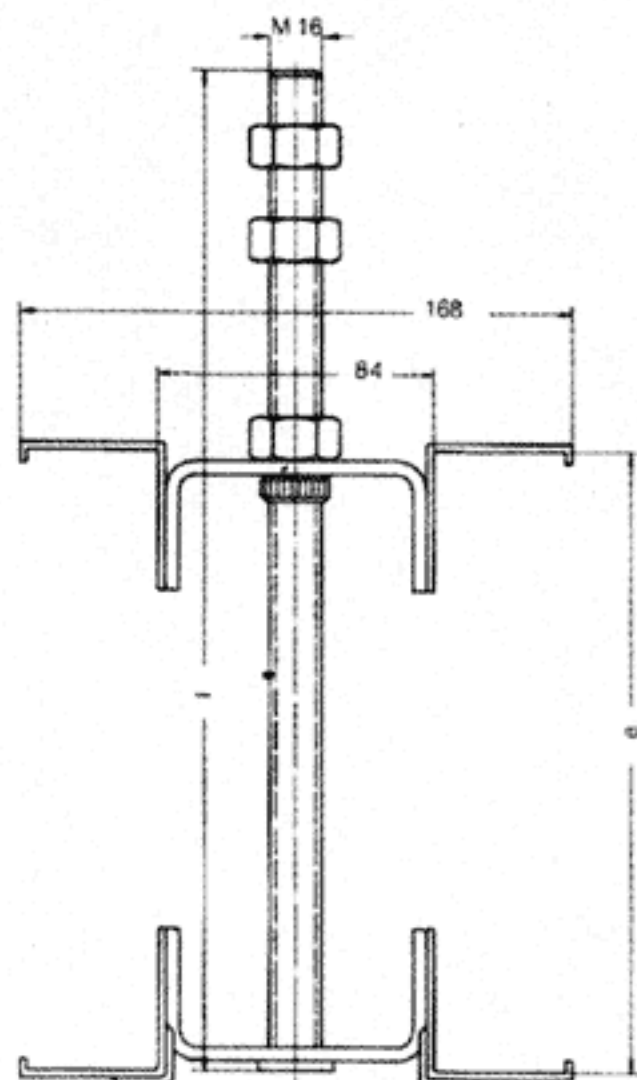

Twin support bracket Galvanized type 30/4/D

Measurement in mm	Type no. of poles					
	KG 30/4/7/8/D	KG 30/4/9/10/D	KG 30/4/11/12/D	KG 30/4/13/14/D	KG 30/4/15/16/D	KG 30/4/17/18/D
e	189,5	223,5	257,5	315	349	383
l	265	305	360	410	440	470

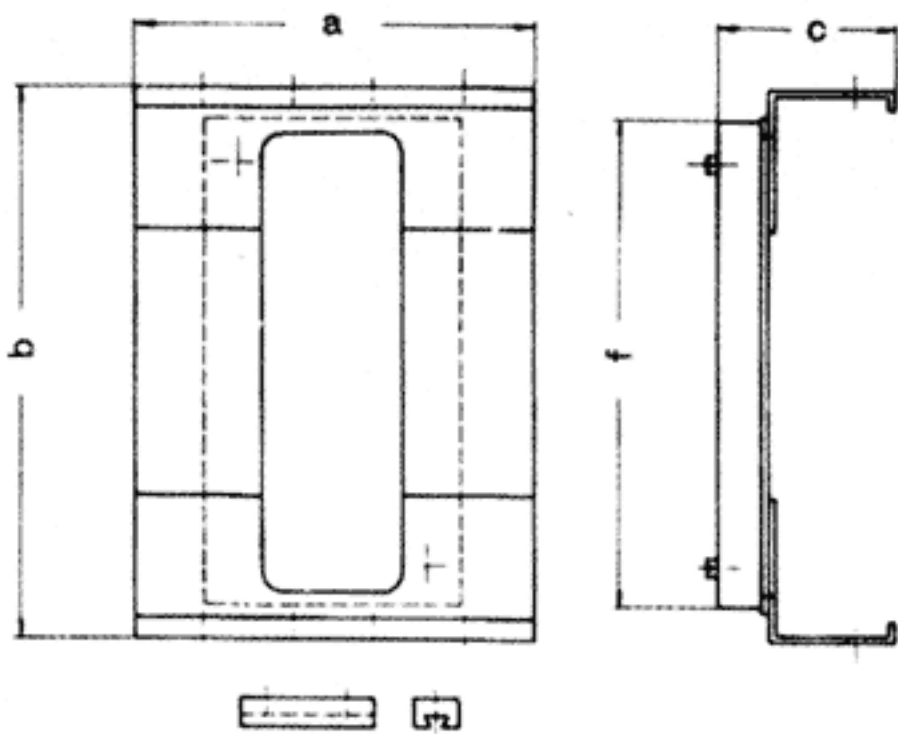

Joint plate VG for electrical and mechanical
connection, connecting sleeves brass nickel
plated with screws.

Measurement in mm	Type no. of pole and capacity					
	VG 7/4/60A/100A	VG 8/4/60A/100A	VG 9/4/60A/100A	VG 10/4/60A/100A	VG 11/4/60A/100A	VG 12/4/60A/100A
a	150	150	150	150	150	150
b	195	229	263	320	354	388
c	61	61	61	61	61	61
f	170	204	238	296	330	364

Power feed in box (end box) for 60 and 100 Amps

For 140 and 200 Amps it is installed in a
1.0 Mtr section

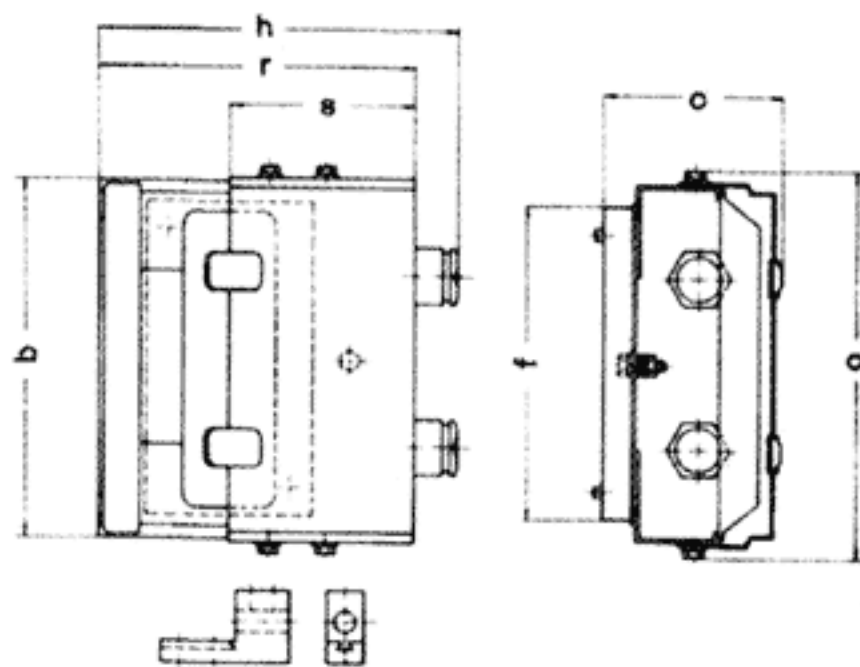

Measurement in mm	Type no. of pole and capacity					
	EGA 7/4/60A/100A	EGA 8/4/60A/100A	EGA 9/4/60A/100A	EGA 10/4/60A/100A	EGA 11/4/60A/100A	EGA 12/4/60A/100A
b	195	229	263	320	354	388
c	95	95	95	95	95	95
h	195	195	195	195	195	195
r	170	170	170	170	170	170
s	100	100	100	100	100	100
o	210	244	278	336	370	404
f	170	204	238	296	330	364

Power conductor SG Profile IV

up to 18 poles 60, 100, 140 and 200 Amps

End Box (without Feed-In)

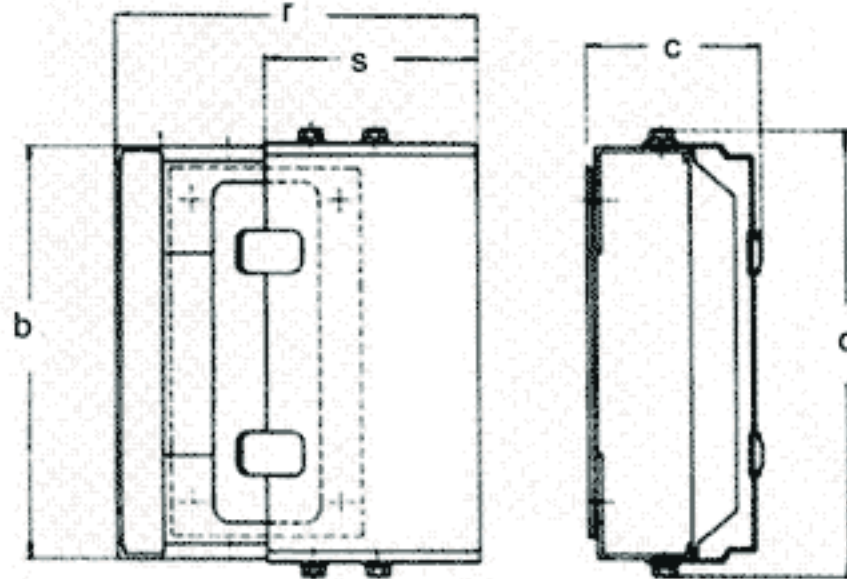

Type no. of poles	EG 1/4/ 7 EG 1/4/ 8		EG 1/4/ 9 EG 1/4/10		EG 1/4/11 EG 1/4/12		EG 1/4/13 EG 1/4/14		EG 1/4/15 EG 1/4/16		EG 1/4/17 EG 1/4/18	
	b	195	229	263	320	354	388					
c	80	80	80	80	80	80						
r	170	170	170	170	170	170						
s	100	100	100	100	100	100						
o	210	244	278	336	370	404						

Measurement in mm

Line Feed-In in section for 60A and 100A

For 140 and 200 Amps it is installed in a 1.0 Mtr section.

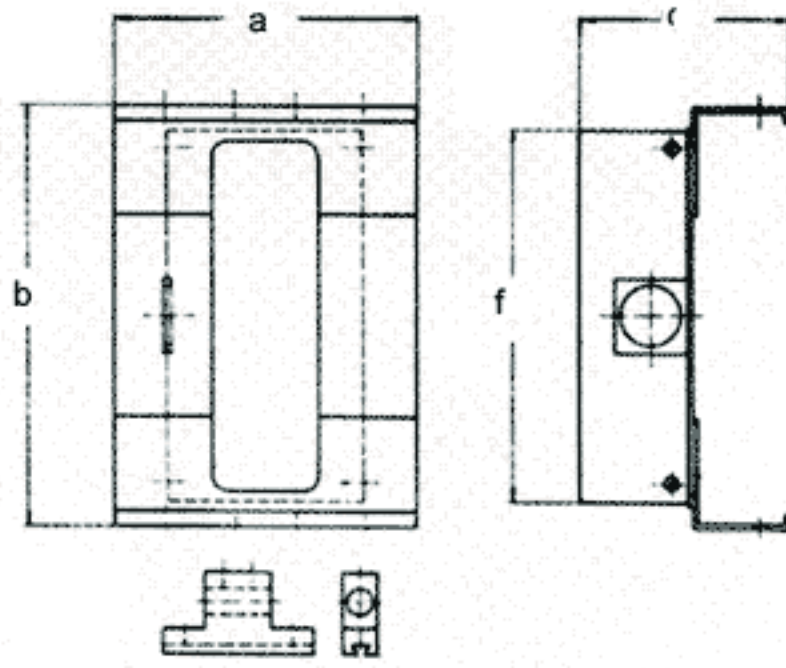

Measurement in mm

	AG 7/4/60A/100A AG 8/4/60A/100A		AG 9/4/60A/100A AG 10/4/60A/100A		AG 11/4/60A/100A AG 12/4/60A/100A		AG 13/4/60A/100A AG 14/4/60A/100A		AG 15/4/60A/100A AG 16/4/60A/100A		AG 17/4/60A/100A AG 18/4/60A/100A	
	a	150	150	150	150	150	150					
b	195	229	263	320	354	388						
c	96	96	96	96	96	96						
f	170	204	238	296	330	364						

Electrical capacity and measurement of the collector trolley

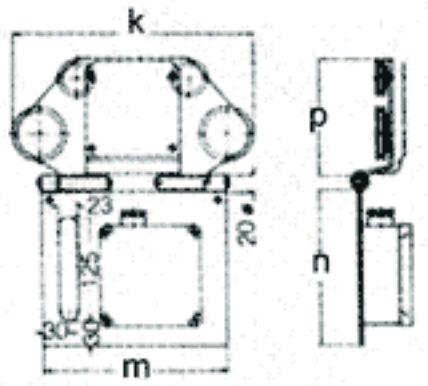

	LGB + LGCM 7/4 + 8/4 EZ/ROHR	LGC + LGR 7/4 + 8/4 EZ/M	LGB + LGCM 9/4 + 10/4 EZ/ROHR	LGC + LGR 9/4 + 10/4 EZ/M	LGB + LGCM 11/4 + 12/4 EZ/M	LGC + LGR 11/4 + 12/4 EZ/M
Capacity amperage	25 + 40	50 + 80	25 + 40	50 + 80	25 + 40	50 + 80
k	315	450	315	500	300	500
m	220	450	220	500	300	500
n	185	110	185	110	110	110
p	202	202	236	236	270	270
EZ connection box fitted to base plate	x	-	x	-	-	-
EZ/M Collector with cable only max. length 2.0 Mts	-	x	-	x	x	x

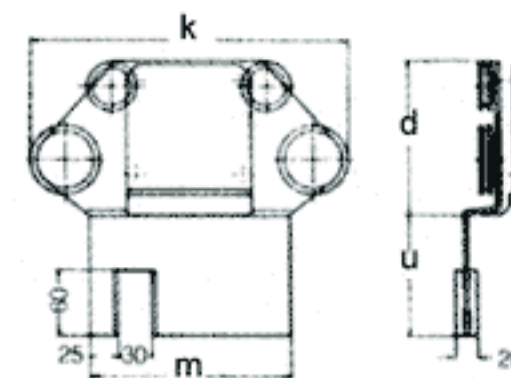

	LGB + LGCM 13/4 + 14/4 EZ/M	LGC + LGR 13/4 + 14/4 EZ/M	LGB + LGCM 15/4 + 16/4 EZ/M	LGC + LGR 15/4 + 16/4 EZ/M	LGB + LGCM 17/4 + 18/4 EZ/M	LGC + LGR 17/4 + 18/4 EZ/M
Capacity amperage	25 + 40	50 + 80	25 + 40	50 + 80	25 + 40	50 + 80
k	300	500	380	500	380	500
m	300	500	440	500	440	500
n	110	110	110	110	110	110
p	328	328	362	362	396	396
EZ connection box fitted to base plate	-	-	-	-	-	-
EZ/M Collector with cable only max. length 2.0 Mts	x	x	x	x	x	x

For further detail see pages 16 and 17

Method of installation

1) Distance of support brackets

2.5 Mts

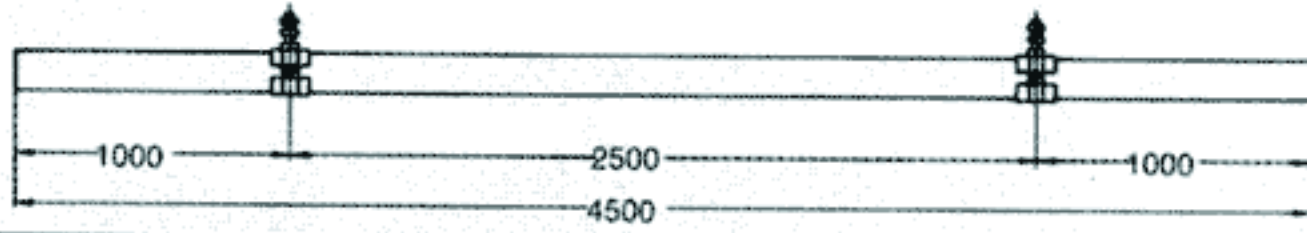

1.5 Mts

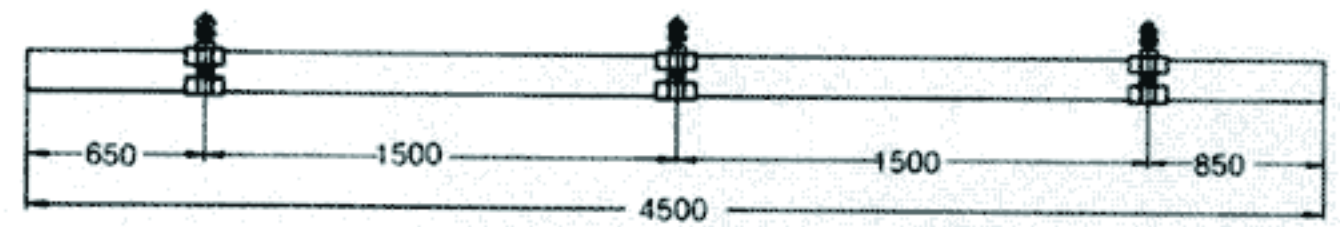

2) Combination of track Examples

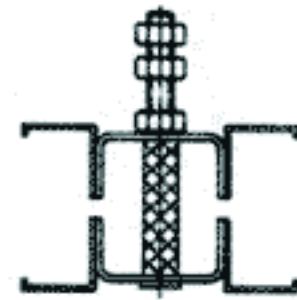

Back to back



Below each other

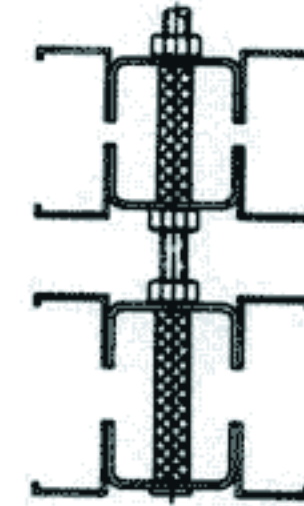

4 Systems

3) Application of installation

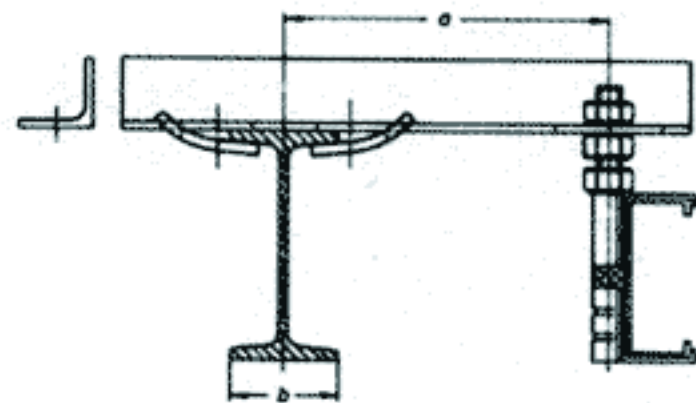

a) **Fitting** from the girder with moveable girder clamp measurement A may be determined by yourself. Please state in your order measurement B and the cross section of the suspension bolt.

Example A = 250 B = 50 ϕ = 12 mm
Type no. AVEZ 12/250/50

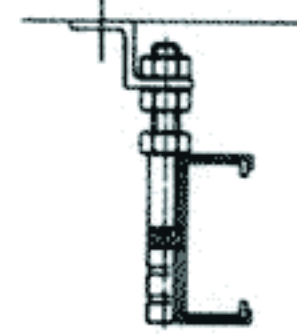

d) **Angled ceiling bracket**

Please state in your order dia of suspension bolt.

Example ϕ 12 mm
Type no. Z12

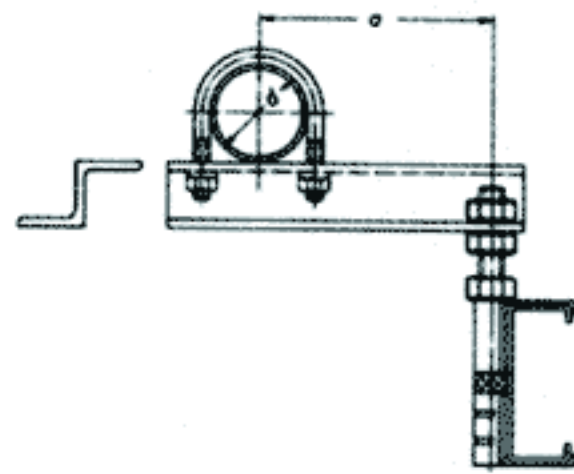

b) **Fitting** from a tube with moveable U clamp measurement A may be determined by yourself. Please state in your order the diameter of the tube and that of the suspension bolt.

Example A = 250 B = 60 ϕ = 12 mm
Type no. R12/250/60

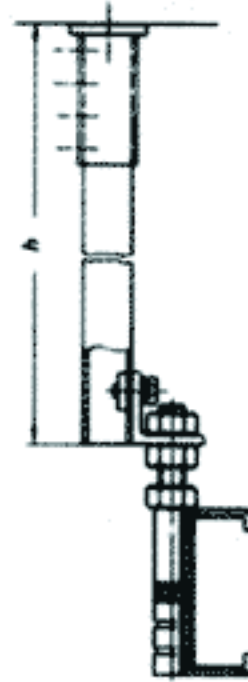

e) **Suspension ceiling bracket**

Please state in your order measurement H and dia of suspension bolt.

Example H = 250 ϕ = 12 · Type no. D 12/250

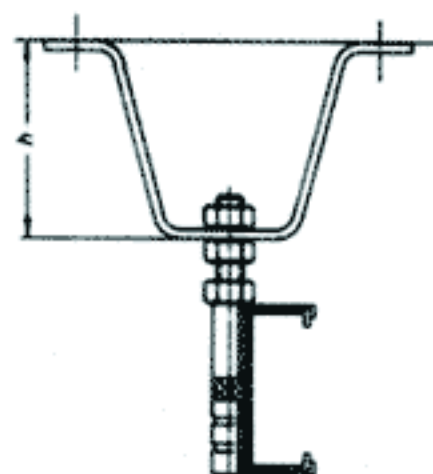

c) **Roof fixing with V bracket**

Measurement H may be determined by yourself. Please state in your order the dia of the suspension bolt.

Example H = 200 Dia = 12 mm
Type no. V12/200

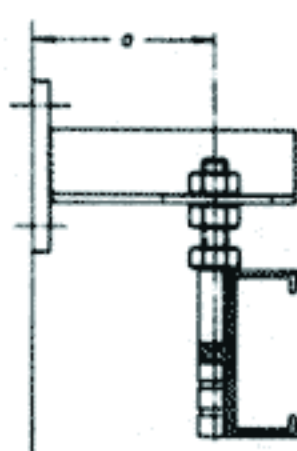

Wall and side fixing bracket

When using this bracket you must install collector trolleys with base plate type EZ/W

Please state the dia of suspension bolt.

Example ϕ = 12 mm A = 250 (not smaller than 150 mm)
Type no. W12/250

Additional components

for profile I to IV

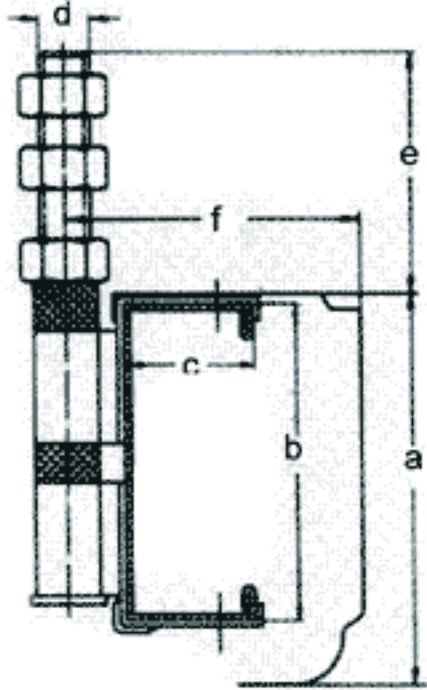

Profile	1	2	3	4
a	111	120,5	154,5	-
b	90	98	132	-
c	22	40	40	40
d	16	16	16	16
e	75	75	75	75
f	69	91,5	91,5	91,5

Measurement in mm

Weatherproof System

With this system you can install SG conductor track outdoors. Please state in your order if this is required, as special pieces are used. Contrary to the normal system the cover has a lip on the rear edge. In this system it is also possible to fit heating elements on bottom ledge of track.

Expansion Section

The length of this section is 1.0 Mtr, copper, housing and cover can more + or - 25 mm. These are to be used in areas where a major change of temperature is experienced in a system or at an expansion section on a girder. The expansion section has a centre clamping, when installing this the screw must be loosened to allow movement of section.

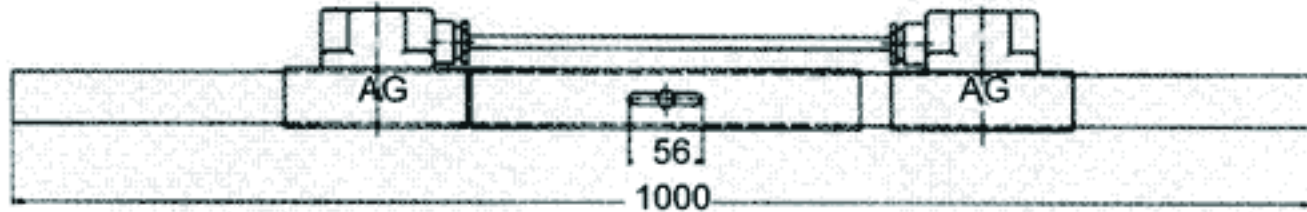

Expansion Joint

This joint piece is made for where you may wish to take up the expansion on contraction of the copper at various points in the system and where no expansion girder is fitted. You must shorten the copper at each of these points by 2 mm insert the special isolating tape.

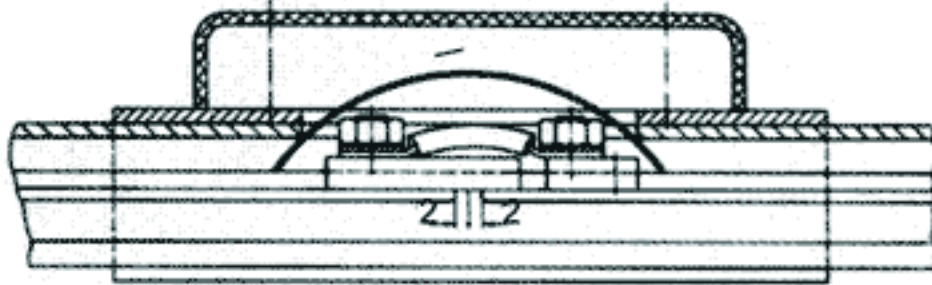

Hinged outlet section AKLA

The section is 500 mm in length but installed in a normal 4.5 Mtr section. Its design is for easy insertion and removal of collector trolley.

Procedure First isolate power supply, push back clips and open lid exposing the trolley, next loosen the two top wheel nuts and slide the axles down, you may now lift the trolley out of the track.

Installing Trolley First place a small sheet of cardboard or such like on front of copper bars, place the trolley on the lower track and push inwards, then slide axles upwards into upper track. Tighten wheel axle nuts, you may now push the trolley either to the right or left and remove the cardboard sheet, check movement of trolley and brushes. Close lid and insert clips.

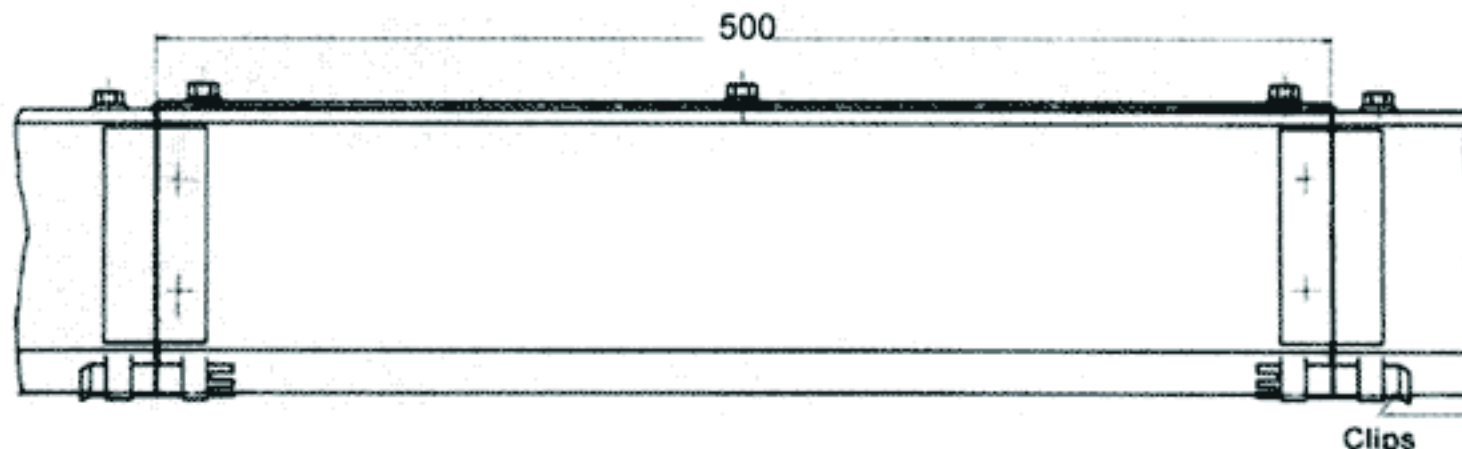

Profile	1	2	3	4
a	90	98	132	-
b	35	40	40	40
c	135	161	195	-

Measurement in mm

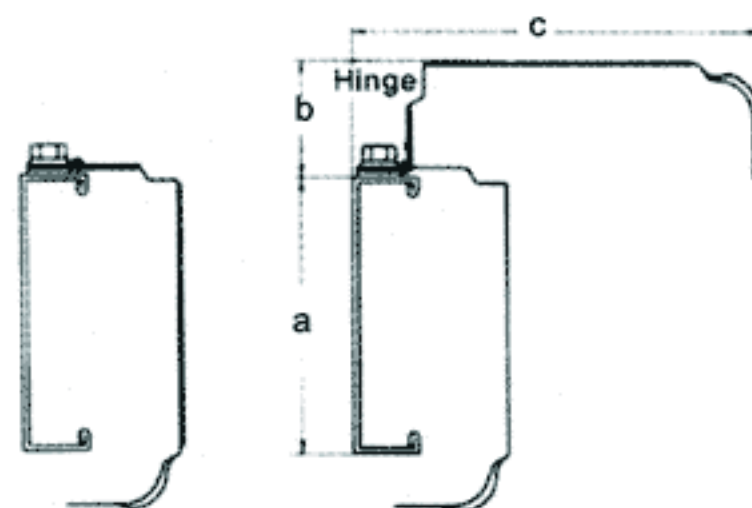

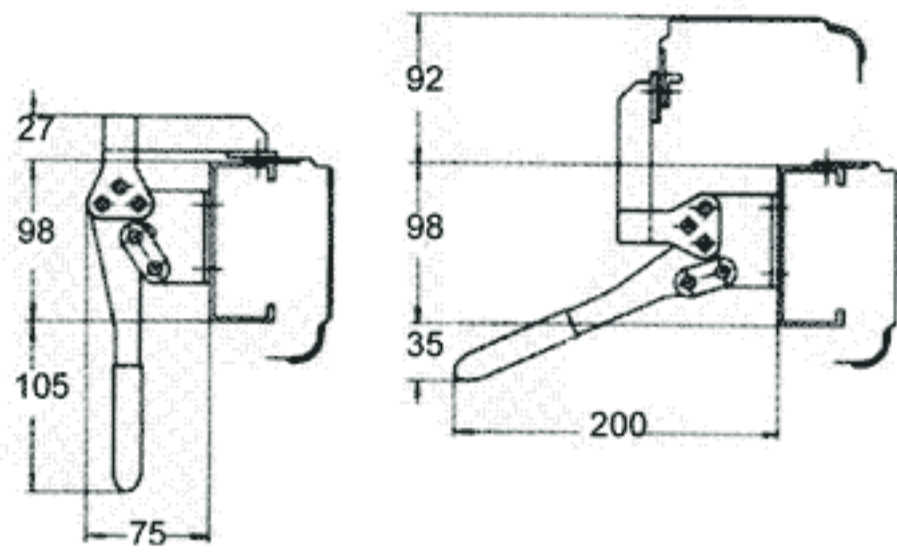

Quick release section AUSV

This section is 350 mm in length but installed in a normal 4.5 Mtr section. Its design is for quick insertion and removal of collector trolley. **Procedure** First isolate power supply, unfasten clips, pull lever, open cover complete with piece of top running track, move trolley into open position and lift out. To replace, first place a small sheet of cardboard over copper bars, place trolley in position and move trolley to left or right. Remove cardboard and close lid, refasten clips.

Rubber gasket (dust proof)

This system is used in areas where dust and powder may enter system and cause problems. The material is Neoprene and the suspension hangers are fixed to the housing and cannot be moved. The trolley is a special type which opens the gasket.

	1	2	3	4
a	111	120,5	154,5	-
b	90	98	132	-
c	22	40	40	40
d	16	16	16	16
e	85	85	85	85
f	67	89,5	89,5	89,5

Measurement in mm

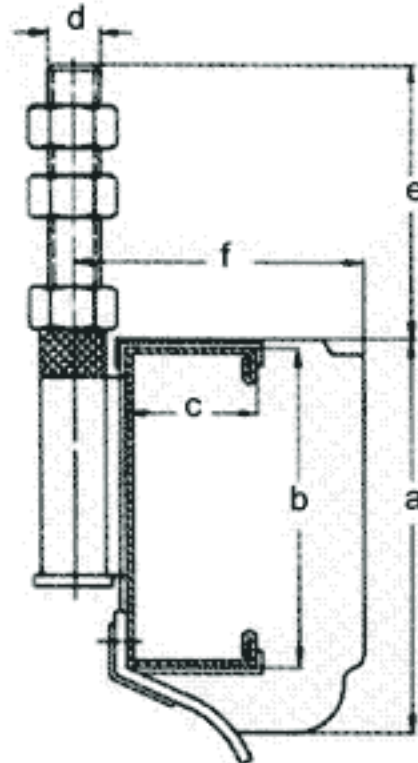

Transfer Section

This section is for moving equipment from one gantry to another. Please note special transfer collector trolleys are used.

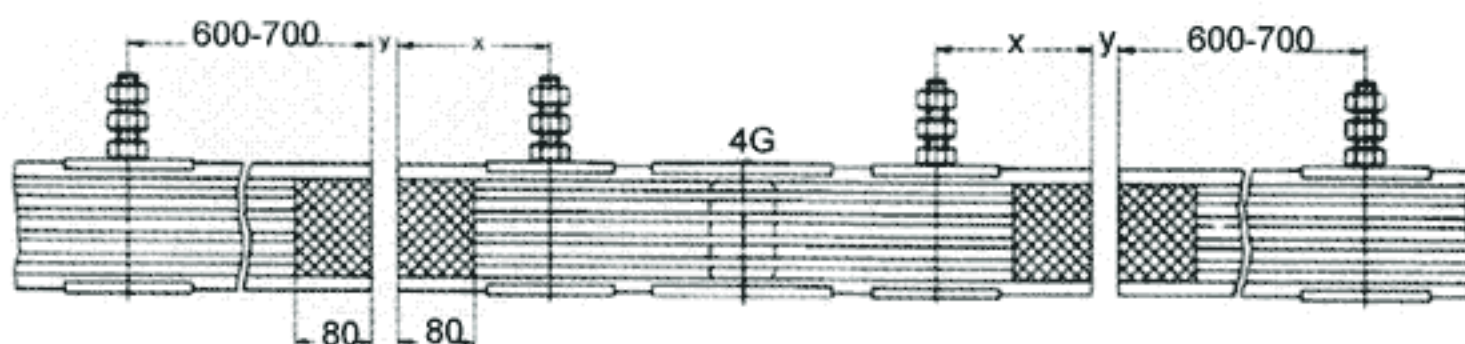

X = Suspension hangers distance must be between 600 - 700 mm
 Y = On straight systems gap max. 30 mm
 Y = For curved systems gap max. 5 mm
 AG = Line Feed-In

Bell mouth sections

These sections are for systems where power may only be required in certain areas. The collector trolley has a special base plate which is fitted to the moving part, it supports and guides the trolley in and out of bell mouth power sections. Please note there must be 10 - 15 mm free movement between the base plate and trolley support bracket.

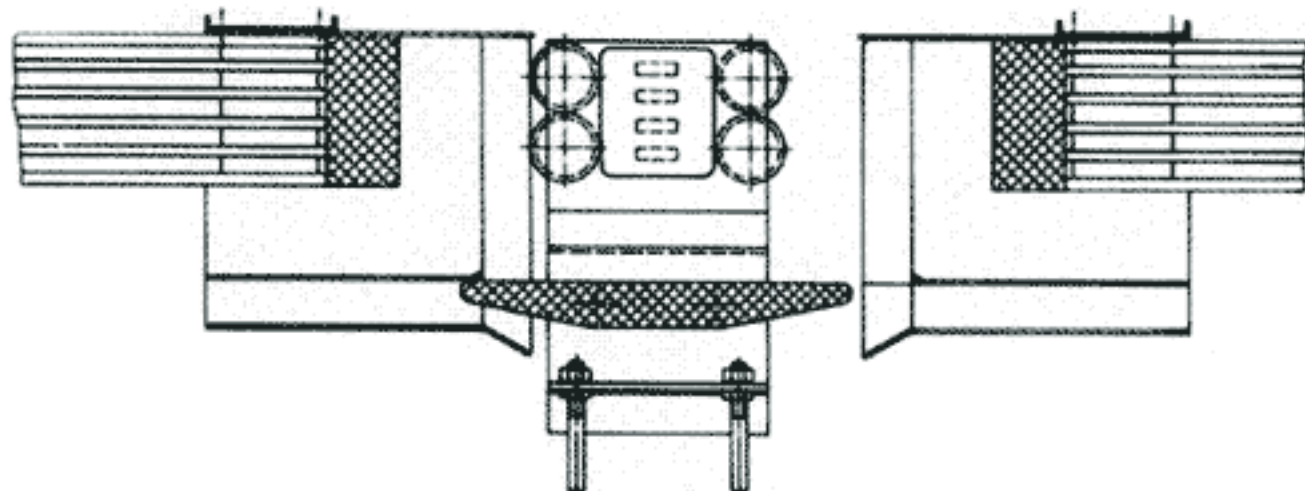

Collector trolley

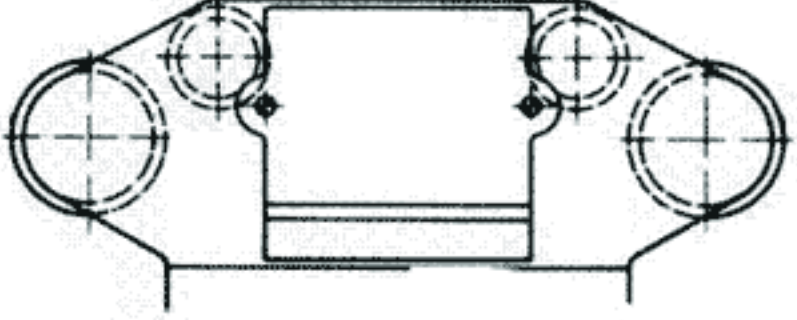
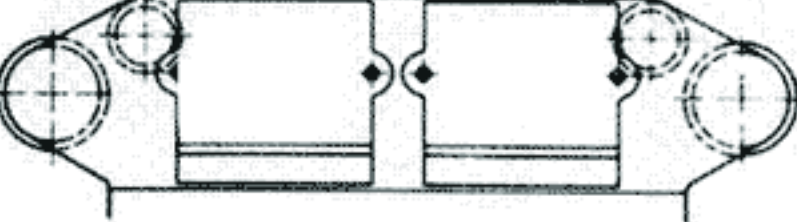
Design	Type	Capacity	No. of brush holders
	LGB	25 A	1
	LGCM	40 A	1
	LGC	50 A	2
	LGR	80 A	2

Base plate fixings examples

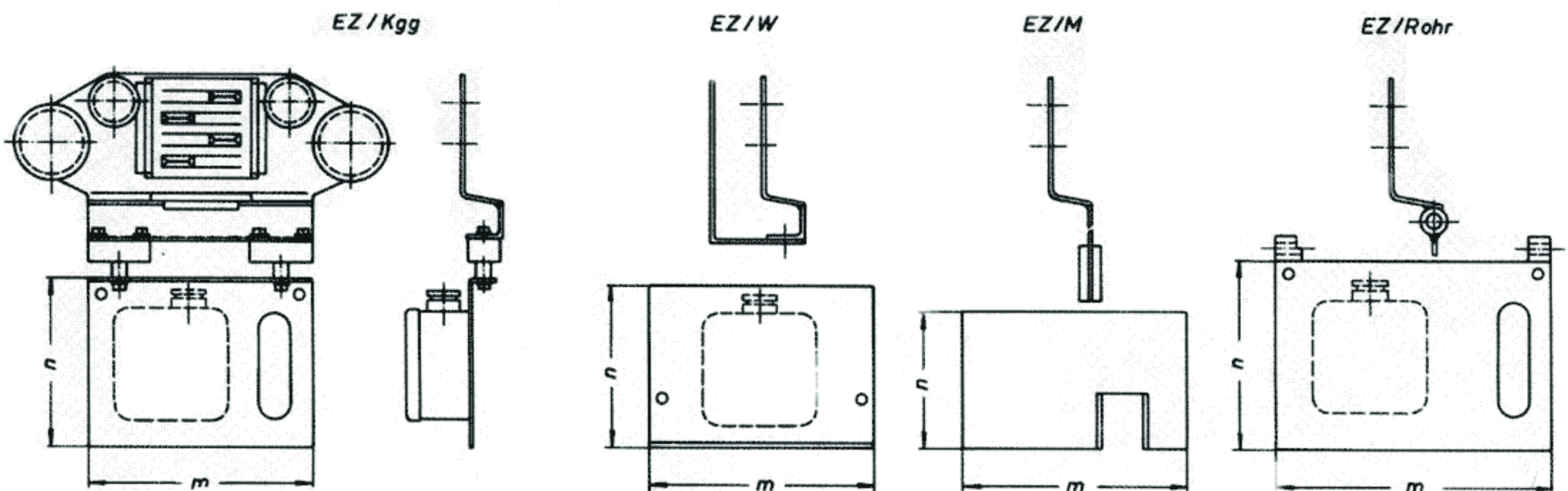

Measurement and types of baseplates								
Type	EZ/Kgg		EZ/W		EZ/M		EZ/Rohr	
	m	n	m	n	m	n	m	n
LGB u. LGCM 4/1	180	135	180	130	180	110	220	150
LGB u. LGCM 4/2	180	135	180	130	180	110	220	150
LGB u. LGCM 6/3	180	185	180	185	180	110	220	185

EZ/KGG This plate is fitted with ball and socket joints at the base of collector normal type if no load is required to be carried.

EZ/W Base plate is secured to the collector. This type is used if no place below the track or if track is fastened to a wall or to machinery.

EZ/M This base plate is welded to collector but hangs below and is used to move to trolley and secure the cables from the collector. Maximum length of cable is 2.0 Mts.

EZ/Rohr This base plate has welded hinges fitted to collector. This type is used for carrying weight for example small tools or to support on the base plate circuit breakers, fuses and plug and socket attachments.

For the textile industry we developed special collector trolleys, they are used to feed in laying and cutting machines, its special advantage is the very easy movement of trolley in track.

Bask plate and bow

MP 01051-1

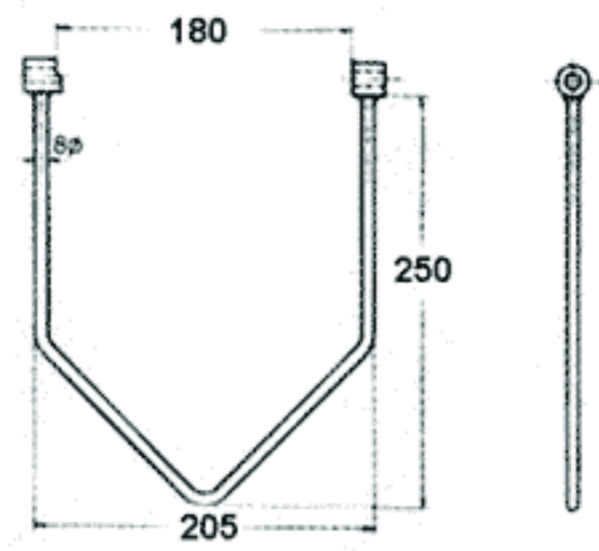

MP 01051-12

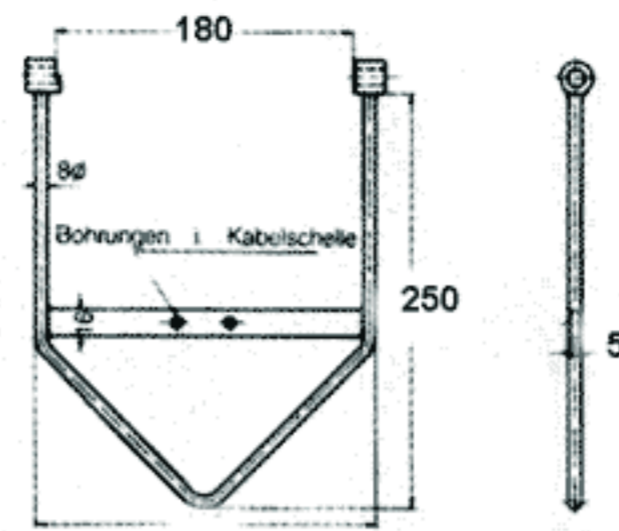

MP 01051-3

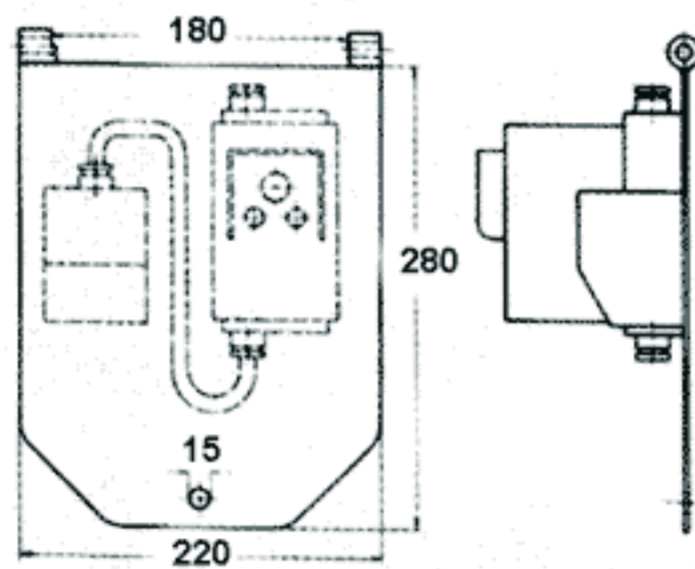

MP 01051-13

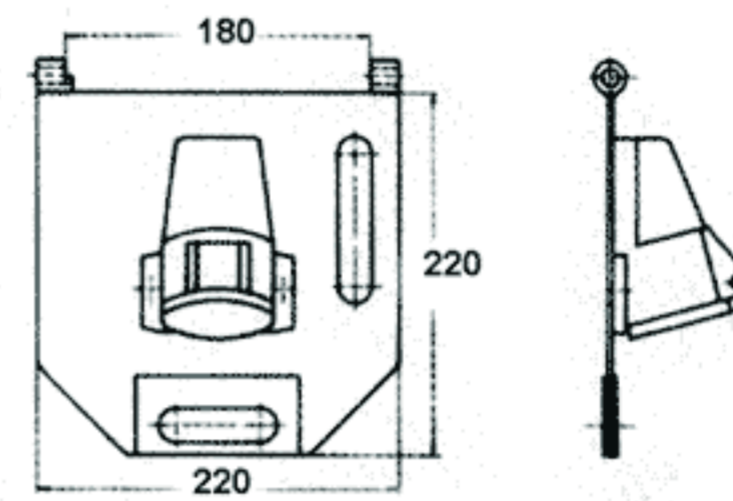

MP 01051-5

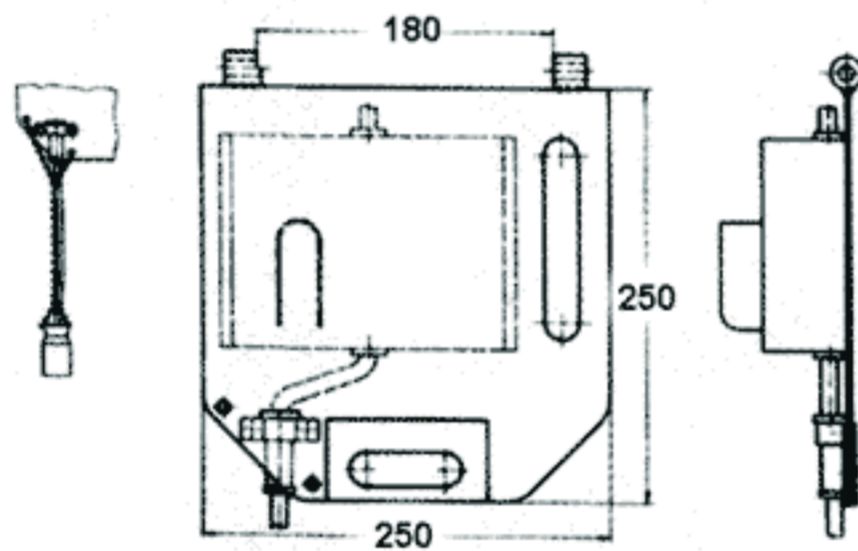

MP 01051-14

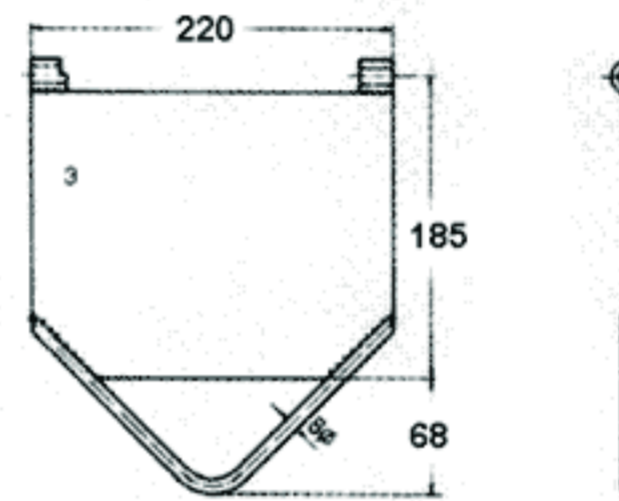

MP 01051-7

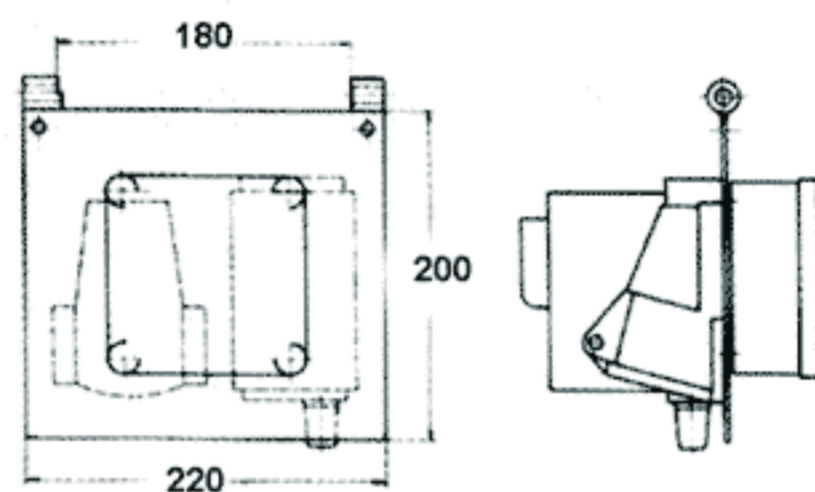

MP 01051-16

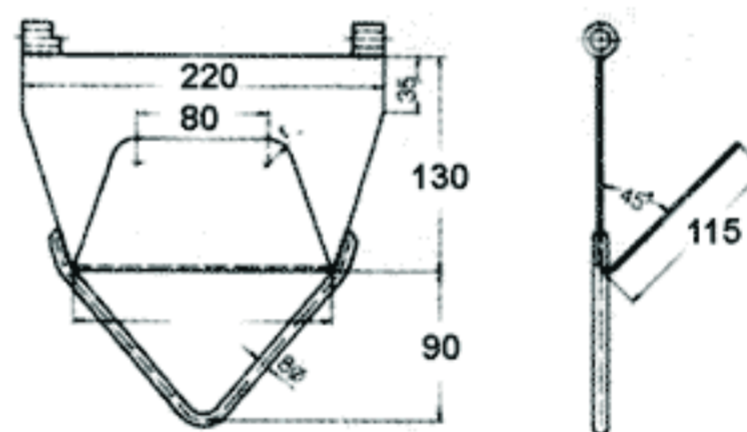

MP 01051-8

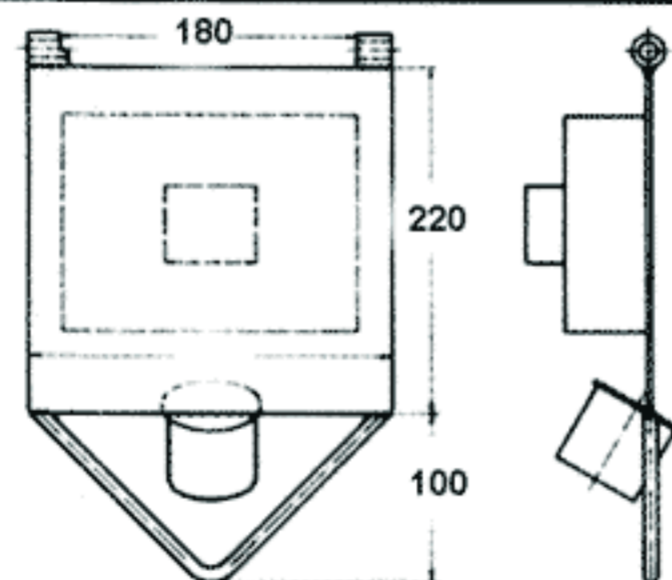

MP 01051-17

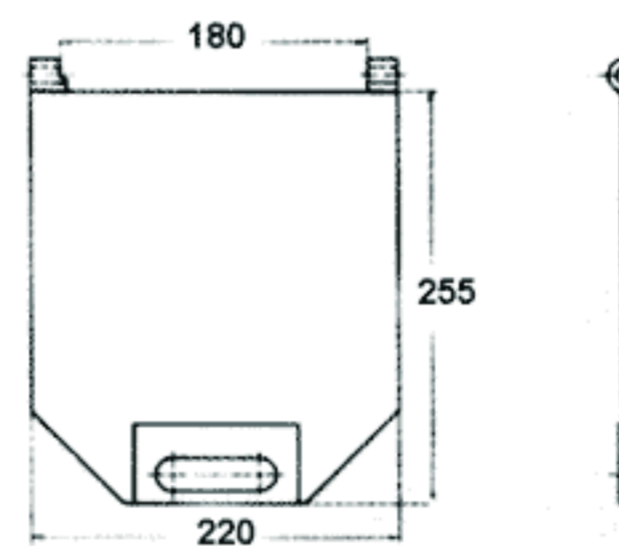

MP 01051-11

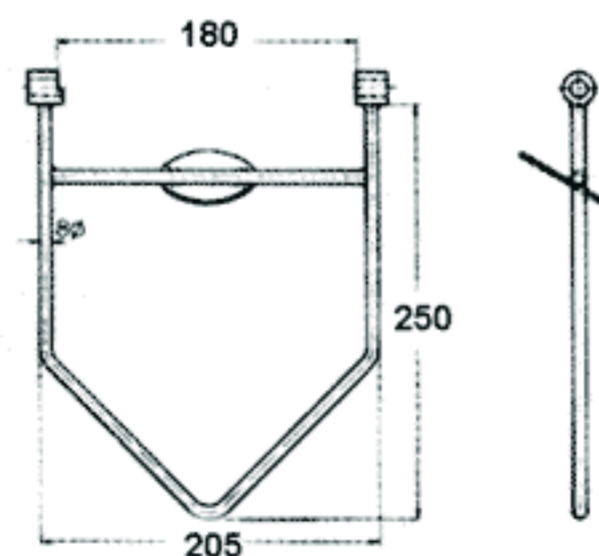

MP 01051-18

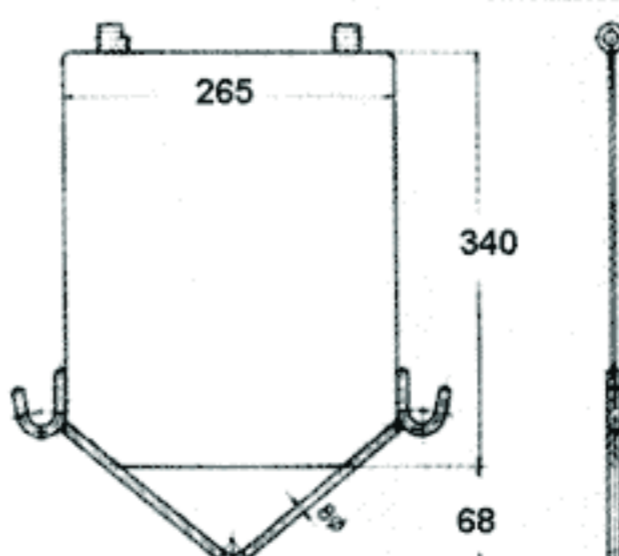

Installation instruction

Metal conductor system SG

Parts list

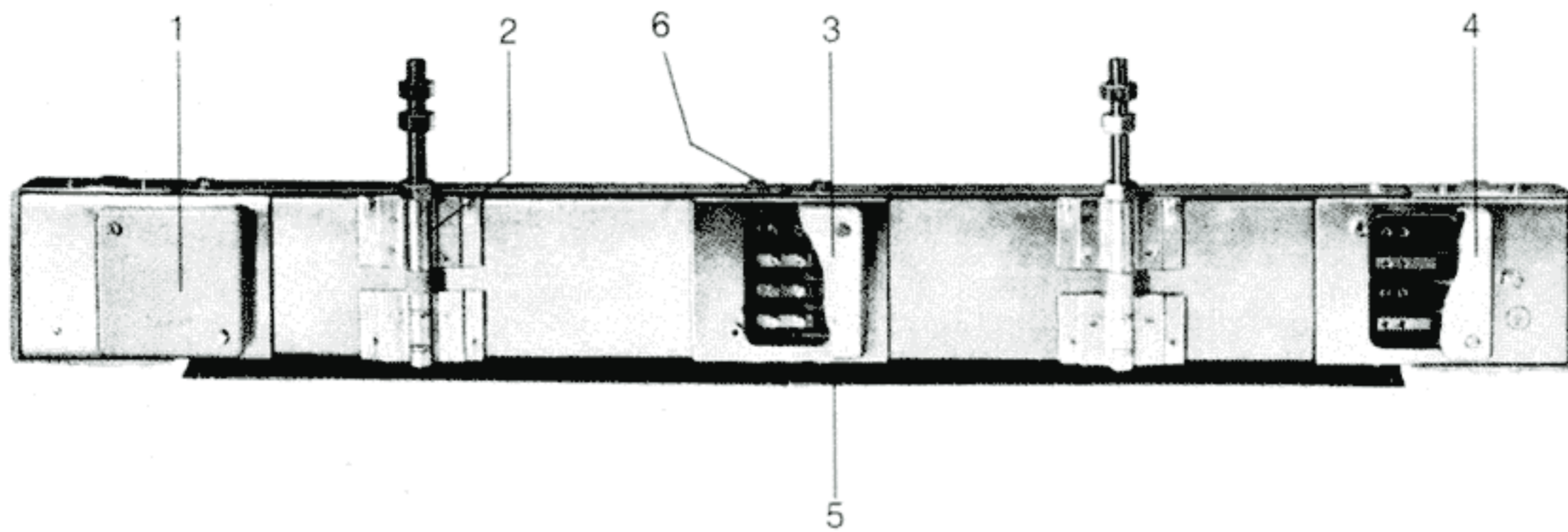

Components:

- | | |
|--|---|
| 1 = End box without power Feed-In | 4 = End Feed-In box with terminals |
| 2 = Bracket | 5 = Flat head screw, used against underside of C-frame only |
| 3 = Joint plate for electrical and mechanical splicing | 6 = Pawl screw, used against top of C-frame only |

Location of supports

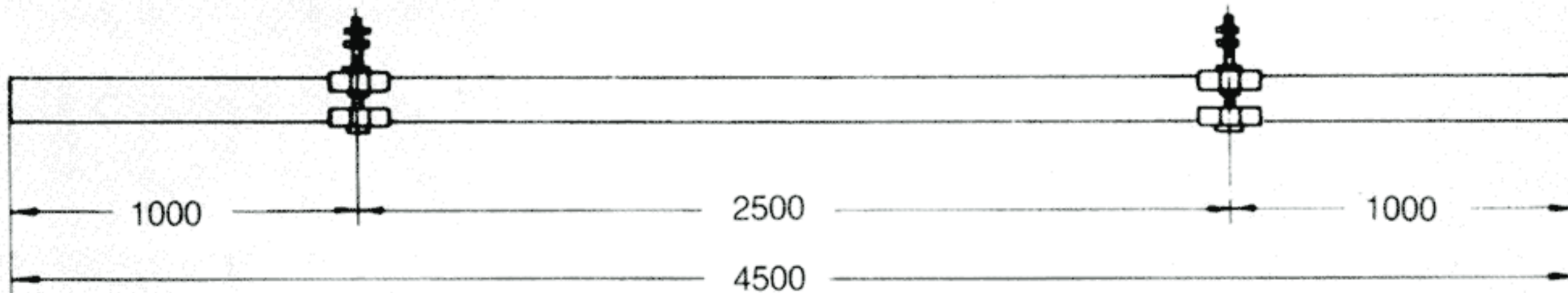

3 supporting brackets are to be used on a standard leg of 4500 mm length, if there is an additional mechanical load of up to 50 kilograms per meter of bus way.

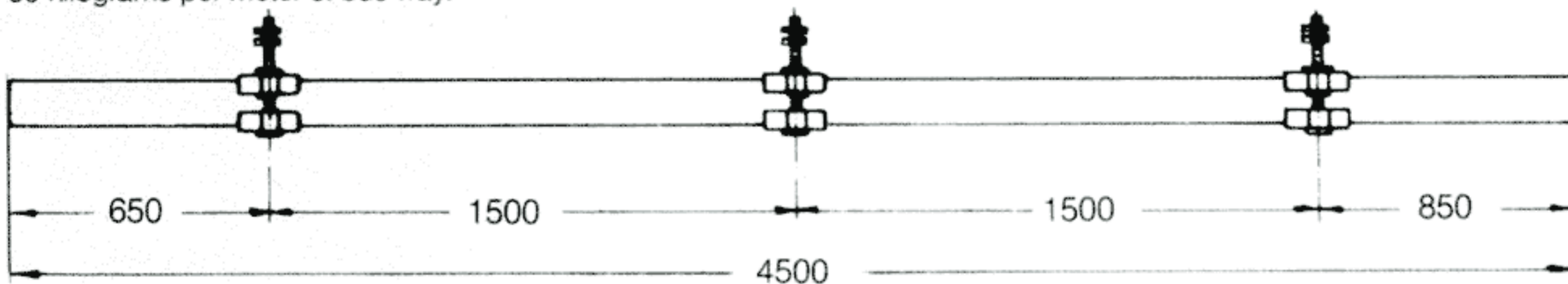

Installation of the Bus Way

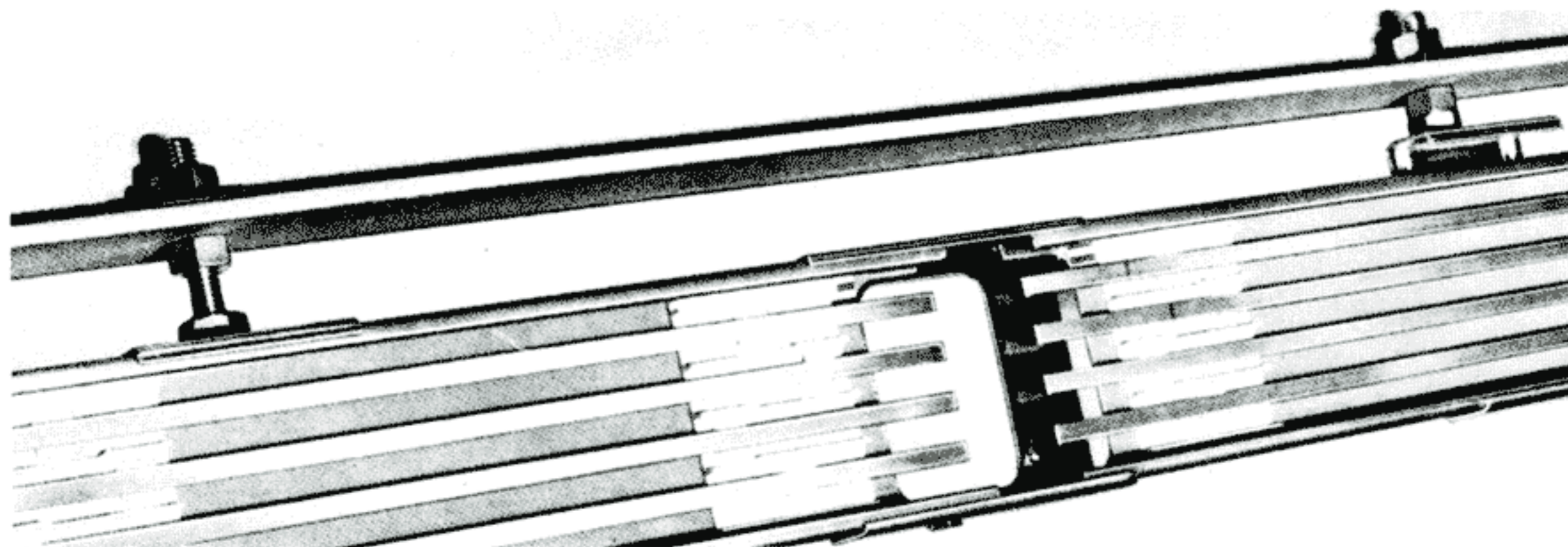

C-shaped trough ends should be joined snugly and wheel bearing surfaces aligned at the joints. Do not displace copper BARS.

Connection of housing and copper bars

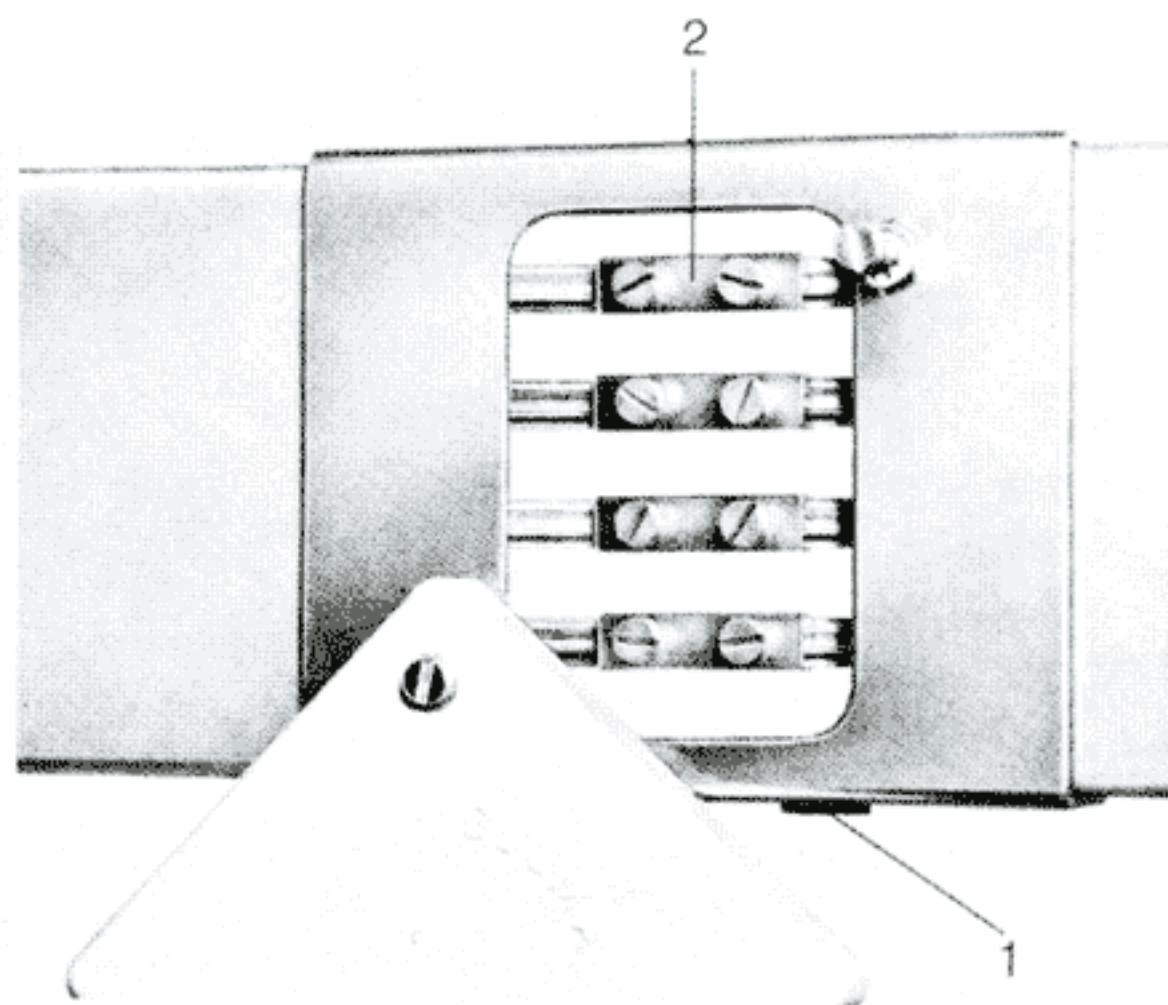

Fasten joint plate to lower side of C-frame with flat head screws (1). Slip one half of connecting sleeves (2) over each bus bar end and tighten.

Installing Sheet Metal Cover

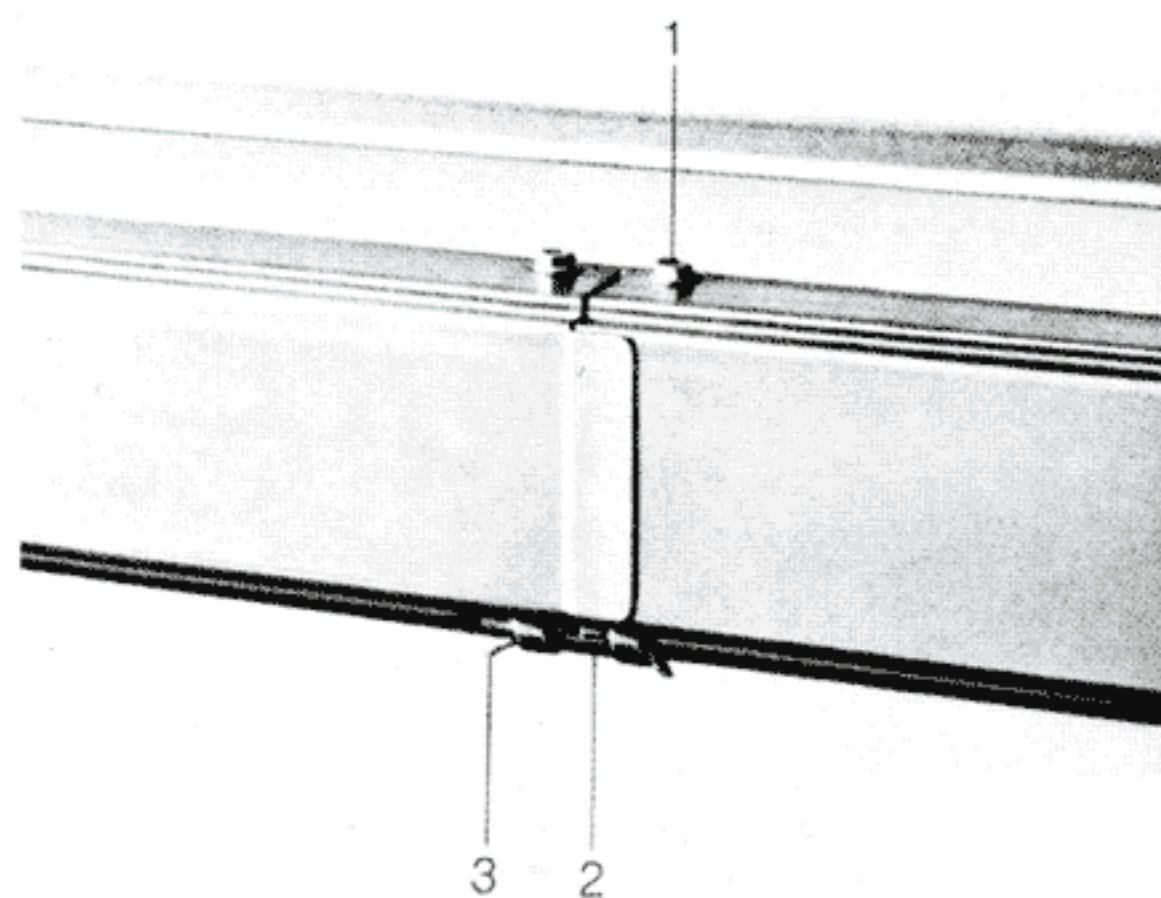

Cover is fastened with pawl screws (1) to C-frame's top side. Two lengths of cover are coupled together at the joint with the help of a latch bolt (2). To secure its pin, center part of it is bent outward slightly.

Inserting Trolley Collector at end of bus bar track

Trolley collector can be inserted at Bus Bar end. Current collector has been tested both mechanically and electrically. When inserting collector, please make sure that all its carbon contact shoes bear against the top of the bars (2).

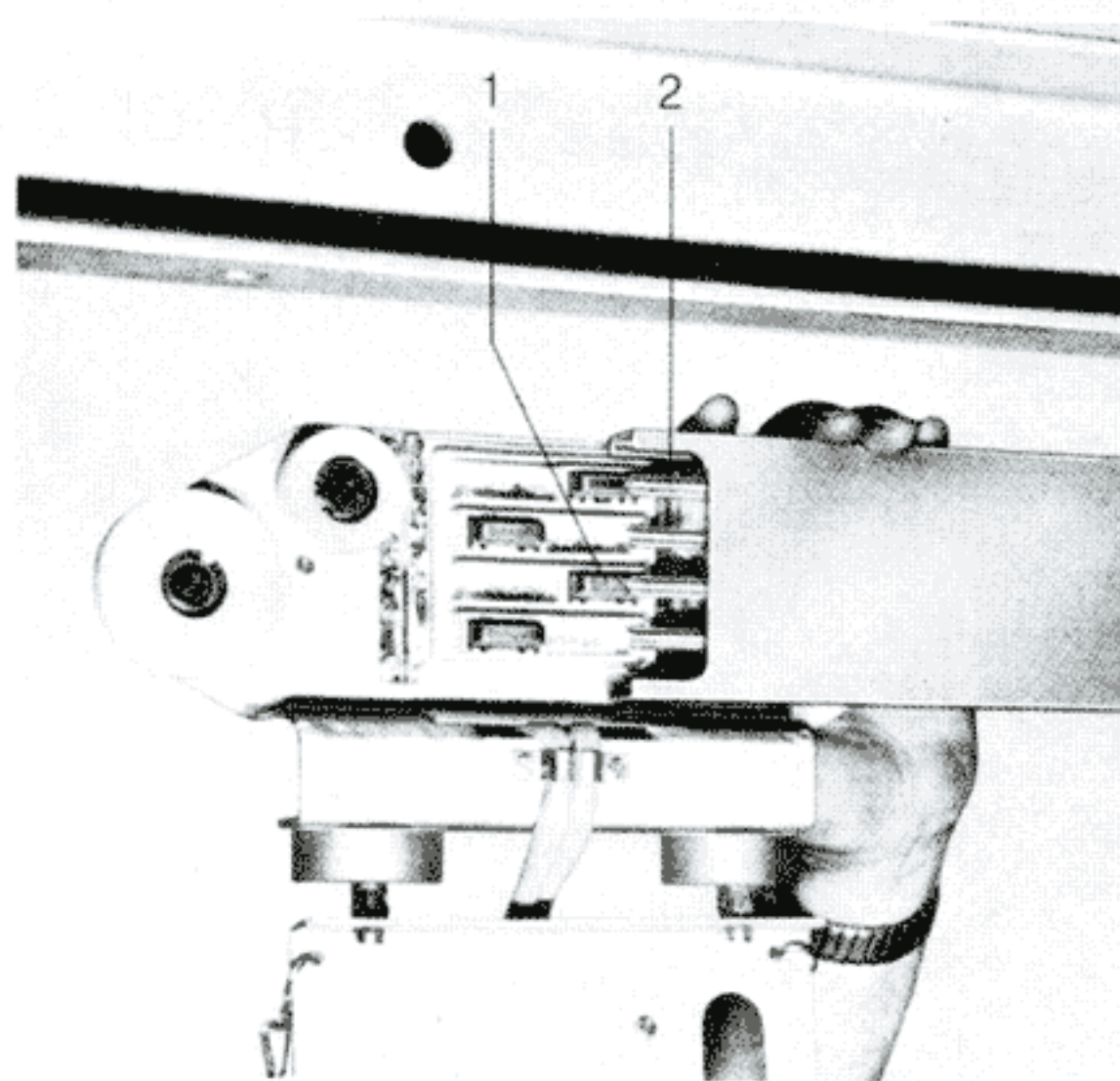

Inserting Trolley Collector anywhere in the system

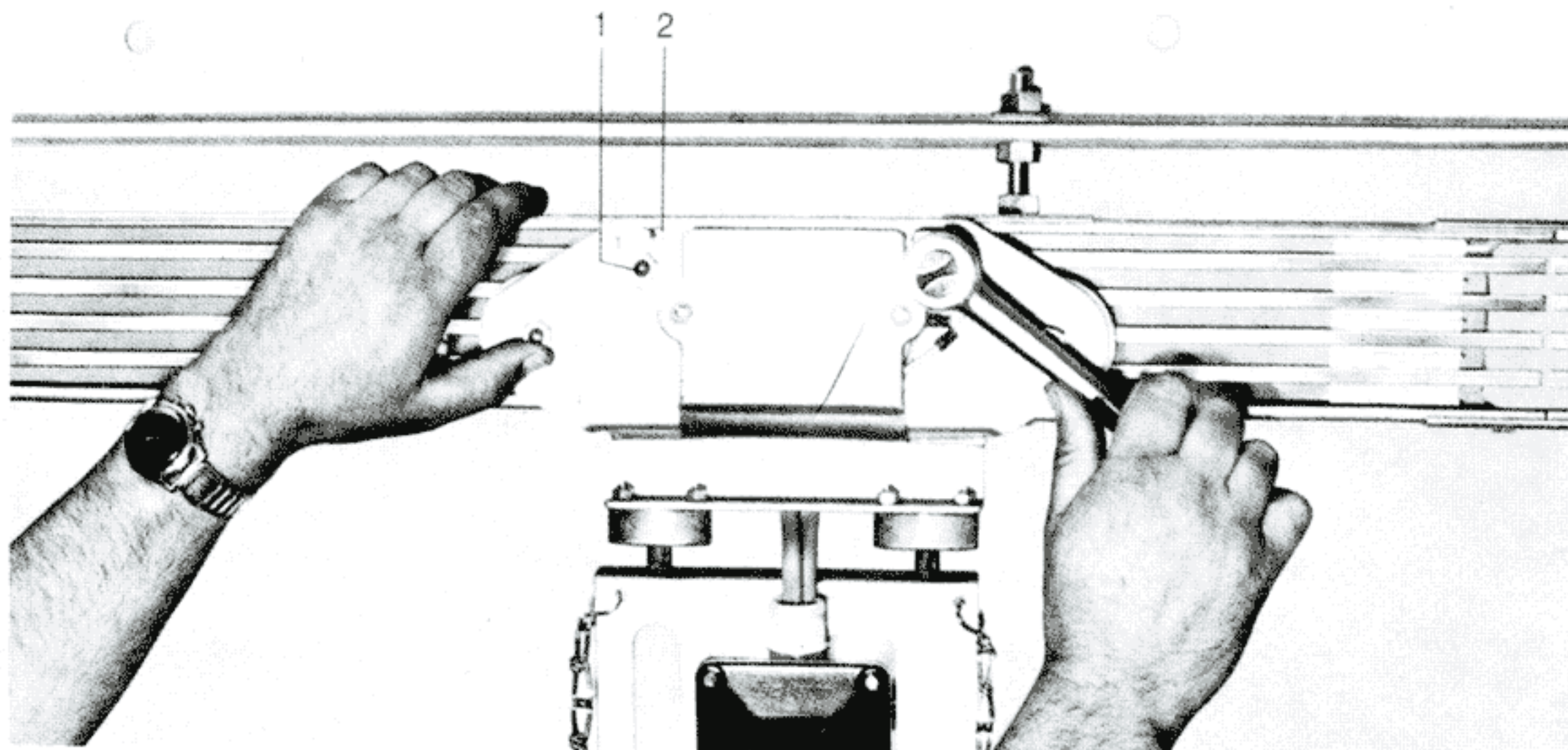

Trolley collector can be inserted into the system anywhere (**Warning isolate power**). First, sheet metal cover is taken off. Then, upper trolley wheels (1) are loosened and set by means of klongatted holes (2).

Different sections used in an installation

- ① Normal 4.5 mtr. section
- ② TRM = interruption with feed-in section
- ③ 90° horizontal outside bend
- ④ 45° horizontal inside bend
- ⑤ Short lengths as required
- ⑥ Turntable arrangement
- ⑦ AG = feed-in section
- ⑧ Cross over arrangement
- ⑨ Horizontal outside or inside bends made to required radius and angle
- ⑩ EGA = end-feed-in box

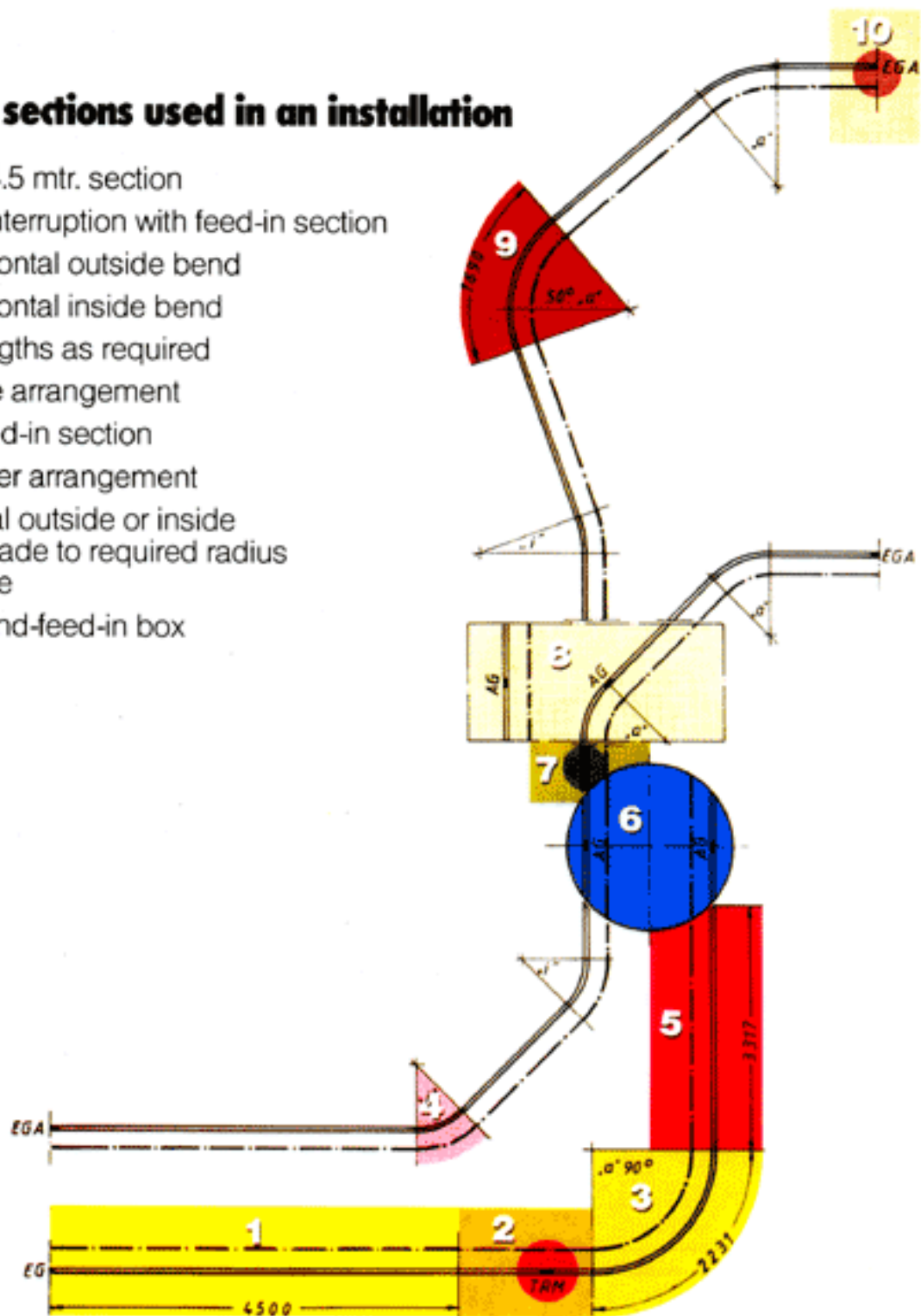

NOVA
ELECTRICAL CO.

20 DIXON PLACE
COLLEGE MILTON
EAST KILBRIDE G74 5JF

TEL: +44(0)1355 234443 FAX: +44(0)1355 247301
e-mail: info@nova.uk.com www.nova.uk.com

